



8 New England Executive Park  
Burlington, MA 01803  
Tel. 781-993-9216  
Fax. 781-993-9217  
Online: <http://www.scanlogic.com>

# SL11RIDE Specification

*Technical Reference*

<b>CONVENTIONS</b> .....	<b>5</b>
<b>DEFINITIONS</b> .....	<b>5</b>
<b>REFERENCES</b> .....	<b>5</b>
<b>1. GENERAL DESCRIPTION</b> .....	<b>6</b>
1.1 OVERVIEW .....	6
1.2 FEATURES OF SL11RIDE.....	6
1.3 APPLICATIONS .....	6
1.4 LOW POWER CONSUMPTION.....	7
1.5 FUNCTIONS FOR SUSPEND, RESUME AND LOW POWER MODES .....	7
<b>2. SERIAL I<sup>2</sup>C INTERFACE</b> .....	<b>9</b>
<b>3. SL11RIDE RESET TIMING</b> .....	<b>9</b>
3.1 RESET CIRCUIT .....	10
3.2 SL11RIDE PIO READ/WRITE CYCLE .....	10
<b>4. SOFTWARE</b> .....	<b>11</b>
4.1 OVERVIEW .....	11
4.2 FIRMWARE .....	11
4.3 WINDOWS HOST DRIVERS.....	11
4.4 MAC HOST DRIVERS .....	12
4.5 MULTI PORT DRIVER SUPPORT .....	12
<b>5. FIRMWARE DOWNLOAD</b> .....	<b>13</b>
5.1 HOW TO UPDATE THE SL11RIDE FIRMWARE .....	13
5.2 QTUI2C.....	13
5.3 OVERVIEW .....	13
5.4 USAGE.....	13
<b>6. PHYSICAL CONNECTION</b> .....	<b>15</b>
6.1 SL11RIDE CHIP DIMENSION .....	15
6.2 SL11RIDE 40 PIN INTERFACE SIGNALS.....	16
<b>7. ELECTRICAL SPECIFICATION</b> .....	<b>17</b>
7.1 ABSOLUTE MAXIMUM RATINGS .....	17
7.2 RECOMMENDED OPERATING CONDITIONS.....	17
7.3 CRYSTAL REQUIREMENTS (XTAL1, XTAL2).....	17
7.4 SL11RIDE USB TRANSCEIVER CHARACTERISTICS.....	18
<b>8. APPENDIX</b> .....	<b>19</b>
8.1 SL11RIDE PIN TRANSLATION: 36-PIN—40-PIN SIGNALS .....	19
8.2 SL11RIDE PIN TRANSLATION: 40-PIN—44-PIN SIGNALS .....	20
8.3 SL11RIDE PIN TRANSLATION: 40-PIN—50-PIN CF CARD SIGNALS.....	21
8.4 SL11RIDE PIN TRANSLATION: 40-PIN—50-PIN SLIM CONNECTOR .....	22
<i>Figure 1 USBPU pull up connection example</i> .....	<i>7</i>
<i>Figure 2 I2C 2K-byte connection</i> .....	<i>9</i>
<i>Figure 3 General View</i> .....	<i>11</i>

*Figure 4 Multi-portable drivers* ..... 12  
*Figure 5 Reset Circuit Sample* ..... 10

*Table 1 Windows Host Software OS compatibility*..... 11  
*Table 2 Mac Host Software OS compatibility*..... 12  
*Table 3 40-pin connector interface signals*..... 16  
*Table 6 36-pin to 40-pin interface signals*. .... 19  
*Table 7 SL11RIDE Pin Translation: 40-Pin—44-Pin Signals* ..... 20  
*Table 8 SL11RIDE Pin Translation: 40-Pin—50-Pin Signals* ..... 21  
*Table 9 SL11RIDE Pin Translation: 40-Pin—50-Pin SLIM Signals*..... 22

### License Agreement

Use of this document and the intellectual properties contained herein indicates acceptance of the following License Agreement. If you do not accept the terms of this License Agreement, do not use this document, nor the associated intellectual properties, nor any other material you received in association with this product, and return this document and the associated materials within fifteen (15) days to ScanLogic Corporation(SL) or SL's authorized distributor from whom you purchased the product.

1. You can only legally obtain SL's intellectual properties contained in this document through SL or its authorized distributors.
2. You are granted a nontransferable license to use and to incorporate SL's intellectual properties contained in this document into your product. The product may be either for your own use or for sale.
3. You may not reverse-engineer the SL11RIDE nor otherwise attempt to discover the designs of SL11RIDE.
4. You may not assign, distribute, sell or transfer or disclose SL's intellectual properties contained in this document to any other person or entity.
5. This license terminates if you fail to comply with any of the provisions of this Agreement. You agree upon termination to destroy this document, stop using the intellectual properties contained in this document and any of its modification and incorporated or merged portions in any form, and destroy any unused SL11RIDE chips.

SL11RIDE is a trademark of the ScanLogic Corporation. All other product names are trademarks or registered trademarks of their perspective owners.

**CONVENTIONS**

1,2,3,4	Number without annotation is decimal
Dh, 1Fh, 39h	Hexadecimal numbers are followed by an “h”
0101b, 010101b	Binary numbers are followed by a “b”
<i>bRequest, n</i>	Word in <i>italics</i> indicated terms defined by USB Specification or by this Specification
SL11RIDE	16-bit RISC processor, which translate from USB to ATAPI/IDE interface.

**DEFINITIONS**

<b>I2C</b>	2-wire Serial flash EEPROM interface.
<b>SL11R_IDE</b>	The SL11R_IDE is 16-bit RISC USB processor, which provides USB to ATAPI/IDE interface on a single chip.
<b>USB</b>	Universal Serial Bus

**REFERENCES**

[Ref11] AT Attachment with Packet Interface Extension (ATA/ATAPI-5)

**Revision History**

<b>Name and Version</b>	<b>Date Issue</b>	<b>Comments</b>
<b>SL11RIDE Spec</b>		
First Draft	November 8, 1999	Specification Preliminary
Rev 0.2 ... 0.9	November 12, 1999	Specification Revision 0.2 ... 0.9
Rev 1.0	November 17, 1999	Specification Revision 1.0
Rev 1.1	December 1, 1999	Specification Revision 1.1 - Add 50 Pin SLIM connector
Rev 1.12	December 5, 1999	Specification Revision 1.1
Rev 1.41	December 7, 1999	Updated for Rev 1.4 software

## **1. GENERAL DESCRIPTION**

### **1.1 Overview**

The SL11RIDE is a low cost, high speed Universal Serial Bus RISC based Controller board. It contains a 16-bit RISC processor with built in SL11RIDE ROM to greatly reduce firmware development efforts. Its serial flash EEPROM interface offers low cost storage for USB device configuration and customer product specific functions. New functions can be programmed into the I2C by downloading it from a USB Host PC. This unique architecture provides the ability to upgrade products, in the field, without changing the peripheral hardware.

### **1.2 Features of SL11RIDE**

- Two-wire serial EEPROM (I2C) interface port, with SL11RIDE ROM firmware support, to allow on board flash EEPROM programming
- Supports 12 MHz/48MHz external crystal or clock.
- 6Kx8 internal Mask ROM with built-in BIOS.
- Supports up to the maximum USB transfer rate of 12 Mbits/sec (1.5Mbytes/sec).
- Power source requires only 3.3Volt, and it can be powered via a USB host PC or a Hub.
- Resume, Suspend, and Low power modes are available.
- Includes the necessary firmware to function as a USB to IDE/ATAPI controller.

### **1.3 Applications**

ScanLogic offers a Developer Kit with all of its product lines. These Developer's Kits include: ATAPI/IDE firmware, multiple peripheral Mini-port class drivers for Windows98/2000, MAC 8.6 or higher available object code, complete ATAPI/IDE solution reference design, and demo board.

The SL11RIDE offers various solutions for USB to IDE/ATAPI peripheral products including HDD, CD-ROM, CD-R/RW, ZIP drives, LS120, MO drives, Compact Flash, Disk on Chip, Tape drives, Smart Media cards, and ORB Drives.

## 1.4 Low Power Consumption

The SL11RIDE offers various power consumption modes. The maximum power consumption at 48 MHz operation including USB is less than 30mA, but on the average it consumes  $\approx 10\text{mA}$ .

The followings are measurements taken under different setups of the SL11RIDE:

Idle Mode:	2.0mA (USB is on, CPU runs at 48MHz)
During Reset:	3.0mA (Reset is held low)
Post Reset:	12.5mA typical at 48Mhz

Max at 4MHz CPU speed:	4.0mA (USB is on)
Max at 32MHz CPU speed:	25.0mA (USB is on)
Max at 48MHz CPU speed:	30.0mA (USB is on)

## 1.5 Functions for Suspend, Resume and Low Power modes

The SL11RIDE's CPU supports suspend, resume, and CPU low power mode. The SL11RIDE BIOS assigns USBPU for the USB DATA+ line pull-up which simulates the USB cable removal or insertion while the USB power is still applied to the board.

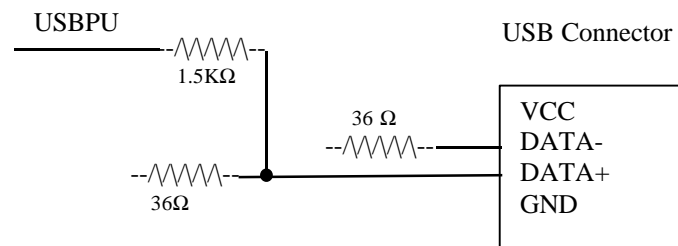

Figure 1 USBPU pull up connection example

### 1.6 PLL Clock Generator

A 48 MHz external crystal can be used with the SL11RIDE. Two pins, X1 and X2, are provided to connect a lower cost crystal circuit to the device. Circuitry is provided to generate the internal clock requirements of the device. If an external 48 MHz clock is available in the application, it may be used in lieu of the crystal circuit by connecting directly to the X1 input pin.

Figure 2: Full-Speed 48MHz Crystal Circuit

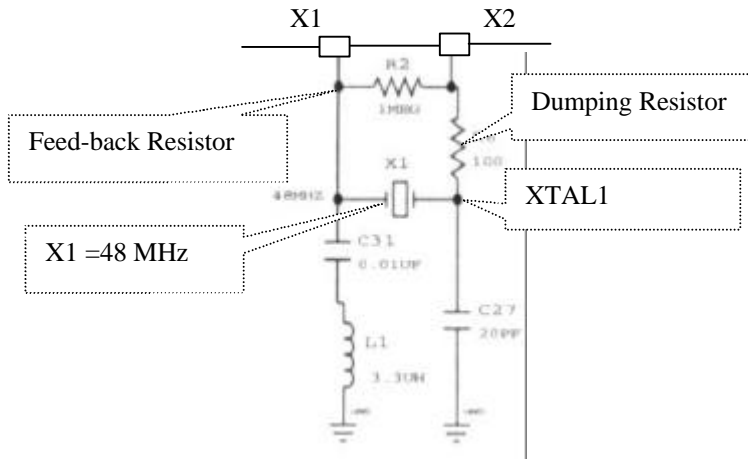
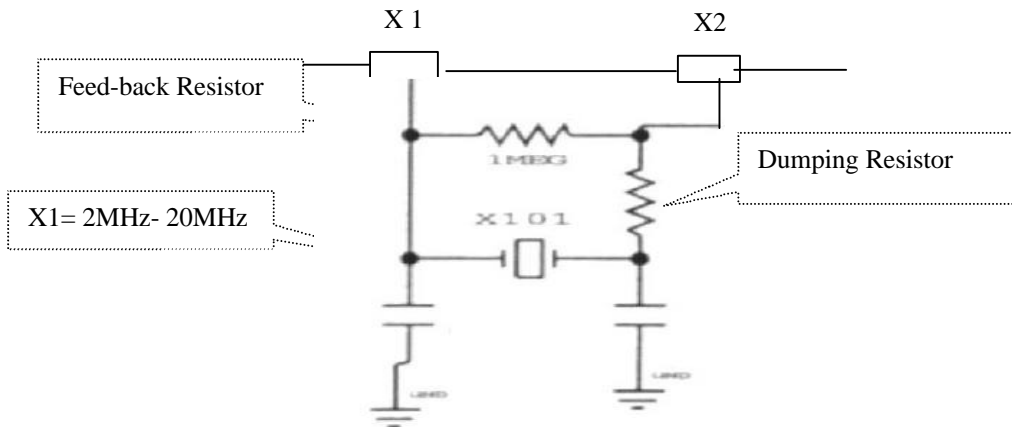

Figure 3: 2MHz-20MHz Low-Speed Crystal



Note: See section 6.3 Crystal Requirements (XTAL1, XTAL2)



## 2. SERIAL I<sup>2</sup>C INTERFACE

The SL11RIDE provides an interface to an external serial flash EEPROM. A variety of serial EEPROM formats can be supported; currently the SL11RIDE firmware supports the two-wire serial flash EEPROM type. It can be used for field product upgrades if needed.

The recommended serial EEPROM device is a 2-Wire Serial CMOS EEPROM (AT24LCXX Device Family). Currently, the SL11RIDE allows writing to EEPROM, up to 2K Bytes, which is 16K bits I2C device (i.e. AT24LC16B/SN).

The USB vendor/device configuration can be programmed and stored into the external EEPROM device. On power-up, the contents of the EEPROM will be downloaded into RAM. The advantage of the I2C/EEPROM interface is both cost and space saving compared with using an external 8-bit PROM/EPROM.

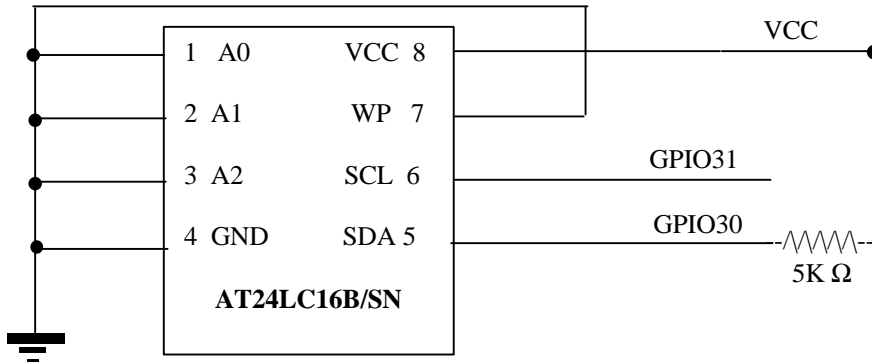
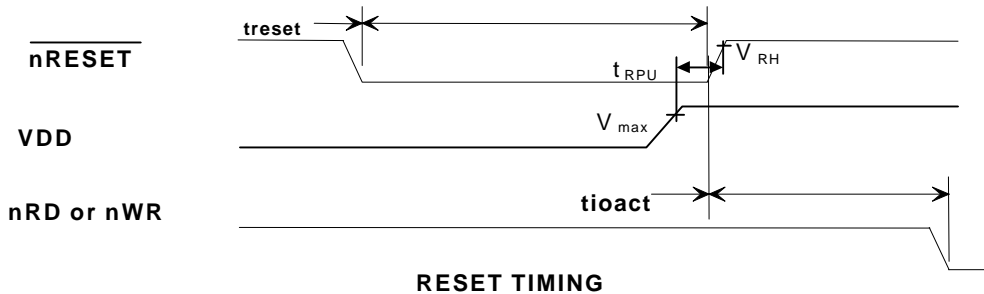

Figure 4 I2C 2K-byte connection

## 3. SL11RIDE RESET TIMING

The nRESET signal from the SL11RIDE chip resets the disk drive. It forces an initialization to occur identical to that after power-up.



Symbol	Parameter	Min.	Typical	Max
VDD	Operating Voltage Range	1.0V		5.5V

$t_{RPU}$	Time Reset Pull up	150ms	350ms	700ms
$V_{max}$	Voltage reach max	VDD-0.7V		
$V_{RH}$	Voltage Reset High	4.35V	4.475V	
treset	nRESET Pulse width	16 clocks		
tioact	nRESET high to nRD	16 clocks		

Note: Clock is 48 MHz nominal.

### 3.1 Reset circuit

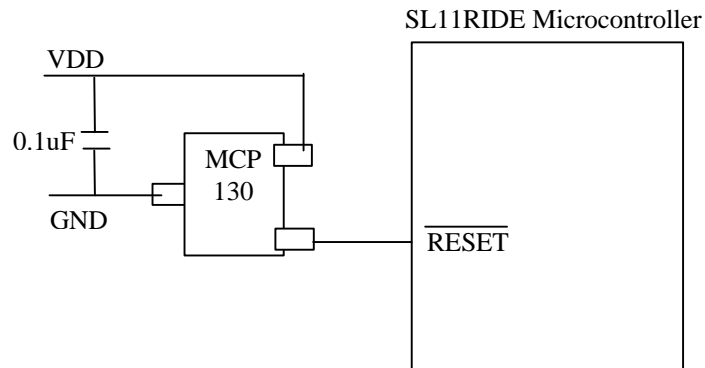

Figure 5 Reset Circuit Sample

### 3.2 SL11RIDE PIO READ/WRITE Cycle

At power-up, the SL11RIDE uses PIO mode 2 timing. During Read/Write Cycles, SL11RIDE uses PIO mode 2 for the data transfer from/to device. See chapter 10 in section 10.2.2 of [Ref11] AT Attachment with Packet Interface Extension (ATA/ATAPI-5) for more detail.

## 4. SOFTWARE

The SL11RIDE software is *USB Specification* and *USB Mass Storage Class Bulk-Only Transport* version 1.0 compliant in the final release. In the meantime, it will try to track changes to the *USB Mass Storage Class Bulk-Only Transport* as closely as possible. The interface to the host PC is USB, which allows true Plug-and-Play (PnP). The requirement for Operating System (OS) on the host PC side is Win98/2000 or MAC.

### 4.1 Overview

This document provides a complete outline description of the SL11RIDE firmware and host mini-port driver under Win98/2000, which supports *Bulk Only Transport* between host PC and SL11RIDE. See Figure 6 General View for details.

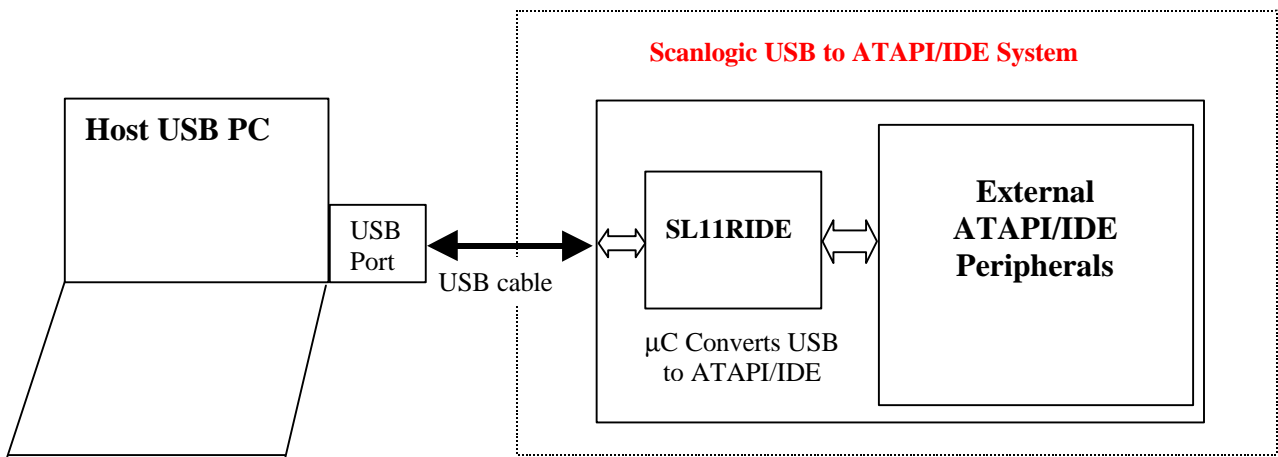

Figure 6 General View

### 4.2 Firmware

SL11RIDE's firmware supports both ATAPI and IDE devices. The firmware is *USB Mass Storage Class* compliant, which supports multiple Operating System such as Windows98/2000 and MAC.

### 4.3 Windows Host Drivers

The WDM and MPD device drivers operate under Windows 98. Win2000 doesn't need any special drivers to be used. See Table 1 Windows Host Software OS compatibility for more detail.

Operation System	USB	Note
Windows98	√	First Edition from Microsoft
Windows98SE	√	Second Edition from Microsoft
Window2000	√	WIN2000 beta from Microsoft
Windows NT	--	NT 4.0 does not support USB

Table 1 Windows Host Software OS compatibility

### 4.4 Mac Host Drivers

ScanLogic does not support end-user update firmware under MAC OS. OEM customers must download firmware from MS-DOS.

Operation System	USB	Note
G3: OS8.6, OS9	√	G3
iMAC: OS8.6, OS9	--	iMAC
Laptop: OS8.6, OS9	--	G3 Laptop

Table 2 Mac Host Software OS compatibility

### 4.5 Multi Port Driver support

Currently SL11RIDE mini-port driver is a multi-device driver for ATAPI/IDE peripherals. This driver supports up to 7 ATAPI/IDE devices, which connect via a USB Hub. See Figure 7 Multi-portable drivers for details.

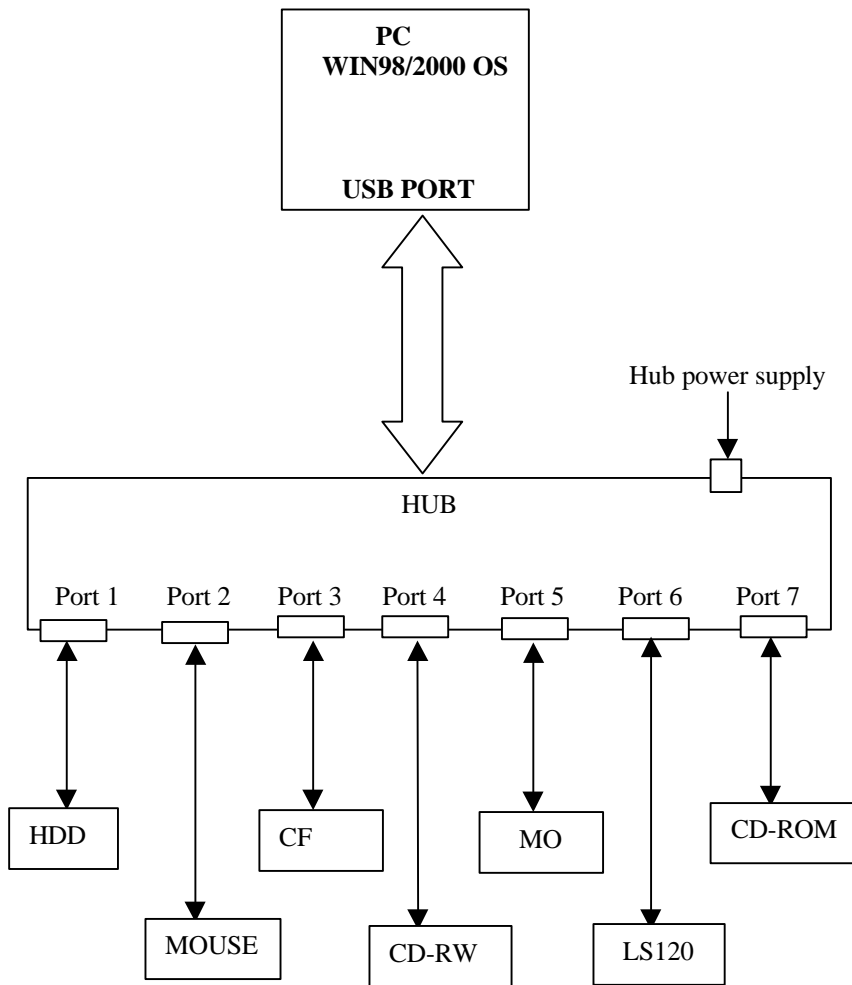

Figure 7 Multi-portable drivers

Note:

- These devices must be “self-powered” since the Hub can not provide enough current to each ATAPI/IDE device.
- The diagram above shows a typical connection.
- We recommend that a PC for this configuration be at least a Pentium II, 300MHz, with 64Mbyte RAM

## **5. FIRMWARE DOWNLOAD**

### **5.1 How to update the SL11RIDE firmware**

The firmware on the EEPROM doesn't have to be changed once it is downloaded for the first time. If it needs to be changed during testing or for future firmware updates, this can be done from a PC using the USB port. The need to change firmware to switch between an ATAPI device and an IDE device will be removed in a future release (1.5).

### **5.2 The QTUI2C Program**

#### **5.2.1 Overview**

The QTUI2C program is used to program the I2C EEPROM that is externally connected to the SL11RIDE chip. This also allows programming the I2C with just data, such as the USB data descriptors. These USB data descriptors must follow the specification for interrupt number 67 (SCAN\_INT) format of the SL11R BIOS Specification.

To program the file, the input filename without the extension is required. The QTUI2C will create a file “MAKEENH.BIN” based on the Object input file. This “MAKEENH.BIN” file will contain the fix-up (.bin) information and it will have a proper format that is defined on the SL11R BIOS specification.

The SL11RIDE will scan the I2C for a valid signature before attempting to load the code and/or data to the internal/external RAM. Any code/data that does not follow the SL11R BIOS specification will not be loaded at power-up.

#### **5.2.2 Usage**

**QTUI2C** <filename | filename.bin>

**Where:**

<Filename> is the output file without extension.

<filename.bin> is the output file with (.bin) extension.

**Note:**

This program is only used when the I2C is connected to the SL11RIDE chip.

Under Windows, if the EEPROM already has a version of the SL11RIDE firmware programmed, it will be necessary to remove the Bulkonly hard disk controller from the Device Manager before this program can be used. Alternately, you can short Pin 5 and Pin 6 of the I2C during the reset of the SL11RIDE. This will prevent the SL11RIDE from loading the program already in the I2C allowing you re-program the EEPROM again.

After this program completes, at any subsequent boot up, the SL11RIDE firmware will automatically scan the I2C and load the code from the I2C into internal/external RAM. However, if the I2C was corrupted, it sometimes causes an unexpected error on USB communication ports.

## 6. PHYSICAL CONNECTION

### 6.1 SL11RIDE Chip Dimension

The SL11RIDE's Package type is 100 PQFP.

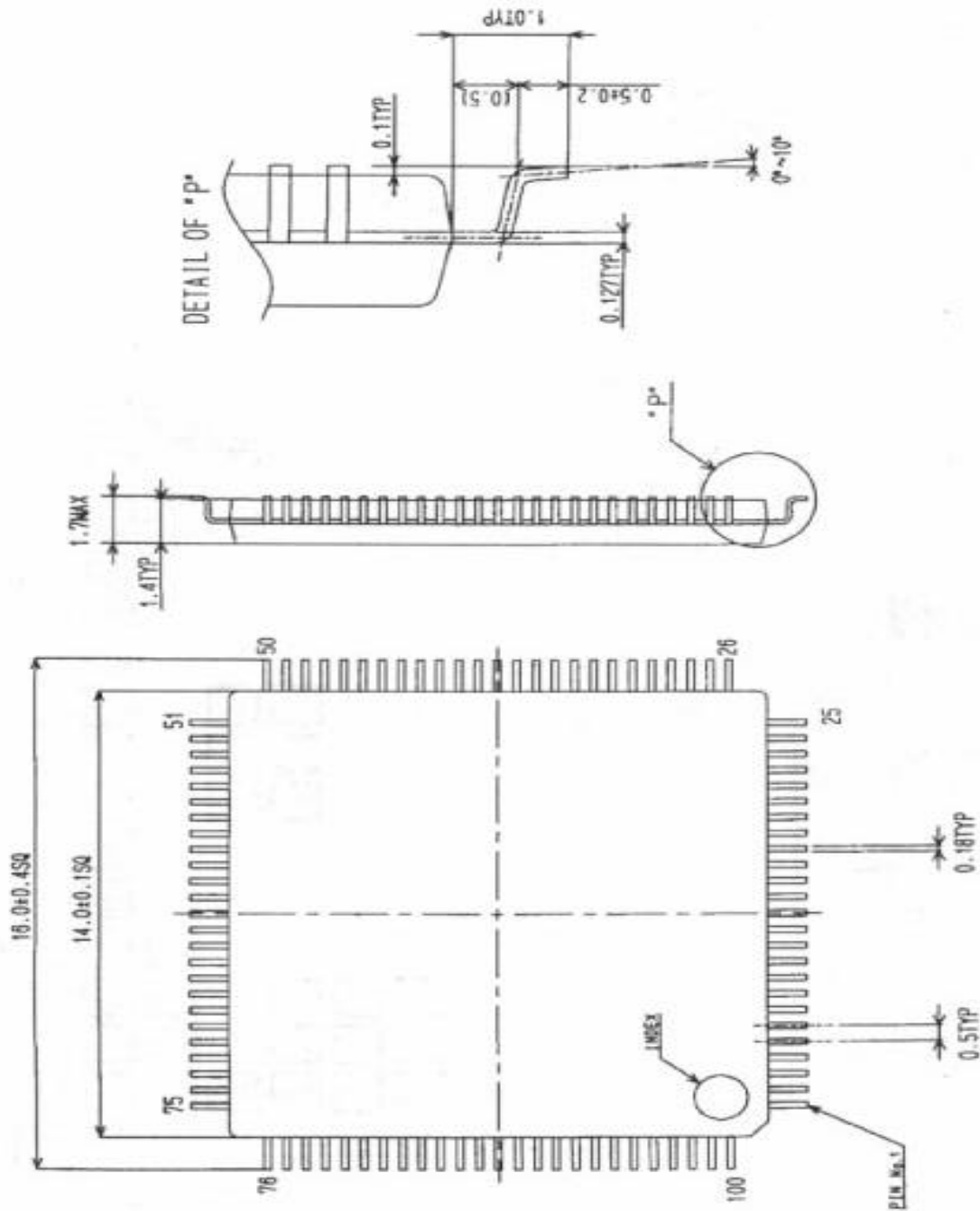

## 6.2 SL11RIDE 40 Pin Interface Signals

Table 3 40-pin connector interface signals

SL11RIDE Signal	IDE Signal	Pin	Pin	IDE Signal	SL11RIDE Signal
RESET	RESET	1	2	GND	GND
D7	DD7	3	4	DD8	D8
D6	DD6	5	6	DD9	D9
D5	DD5	7	8	DD10	D10
D4	DD4	9	10	DD11	D11
D3	DD3	11	12	DD12	D12
D2	DD2	13	14	DD13	D13
D1	DD1	15	16	DD14	D14
D0	DD0	17	18	DD15	D15
GND	GND	19	20	Key	(See Note <sup>2</sup> )
(See Note <sup>1</sup> )	DMARQ	21	22	GND	GND
nWR (See Note <sup>4</sup> )	DIOW	23	24	GND	GND
nRD (See Note <sup>4</sup> )	DIOR	25	26	GND	GND
(See Note <sup>1</sup> )	IORDY	27	28	CSEL	GND (See Note <sup>3</sup> )
(See Note <sup>1</sup> )	DMACK	29	30	GND	GND
INTRQ	INTRQ	31	32	IOCS16	Note <sup>1</sup>
A1	DA1	33	34	PDIAG	Note <sup>1</sup>
A0	DA0	35	36	DA2	A2
CS0 (See Note <sup>4</sup> )	CS0	37	38	CS1	CS1 (See Note <sup>4</sup> )
DASP	DASP	39	40	GND	GND

**Note:**

1. These signals need 5.6k ohms pull up
2. The Key pin must be not be connected
3. CSEL connects to GND for default Cable select and Master modes
4. These signals need 5.6k ohm pull up



## 7. ELECTRICAL SPECIFICATION

### 7.1 Absolute Maximum Ratings

This section lists the absolute maximum ratings of the SL11RIDE. Stresses above those listed can cause permanent damage to the device. Exposure to maximum rated conditions for extended periods can affect device operation and reliability.

Storage Temperature	-40°C to 125°C
Power Supply Voltage (VDD)	3.3V±10%
Power Supply Voltage (VDD1)	3.3V±10%

### 7.2 Recommended Operating Conditions

Parameter	Min.	Typical	Max
Power Supply Voltage, VDD	3.0 V	3.3v	3.6 V
Power Supply Voltage, VDD1	3.0 V		3.6 V
Operating Temperature	0°C		65°C

### 7.3 Crystal Requirements (XTAL1, XTAL2)

Crystal Requirements, (XTAL1, XTAL2)	Min.	Typical	Max
Operating Temperature Range	0°C		65°C
Series Resonant Frequency		48MHz	
Frequency Drift over Temperature			+/- 20 ppm
Temperature Stability			+/- 100 ppm
Accuracy of Adjustment			+/- 30 ppm
Mode of Vibration 3 <sup>rd</sup> Overtone			
Series Resistance	50 ohms		100 ohms
Load Capacitance			20 pf
Shunt Capacitance	3 pf		7 pf
Driver Level	20 microwatt		5miliwatt

#### 7.4 SL11RIDE USB Transceiver Characteristics

Symbol	Parameter	Min.	Typical	Max
V <sub>IHYS</sub>	Hysteresis On Input (Data+, Data-)	0.1 V		200 mV
V <sub>USBIH</sub>	USB Input Voltage HIGH		1.5 V	2.0 V
V <sub>USBIL</sub>	USB Input Voltage LOW	0.8 V	1.3 V	
V <sub>USBOH</sub>	USB Output Voltage HIGH	2.2 V		
V <sub>USBOL</sub>	USB Output Voltage LOW			0.7 V
Z <sub>USBH</sub>	Output Impedance HIGH STATE	24 Ohms		43 Ohms
Z <sub>USBL</sub>	Output Impedance LOW STATE	24 Ohms		43 Ohms
I <sub>USB</sub>	Transceiver Supply p-p Current (3.3V)			< 220uA

**Notes:**

All typical values are VDD2 = 3.3 V and TAMB= 25°C.

Z<sub>USBX</sub> Impedance Values includes an external resistor of 24 --43 Ohms ± 1%

## 8. APPENDIX

This is a pin translation of SL11RIDE signals to 36, 44, 50, and 68 of the Storage Device Class, which is based on the latest AT Attachment specification and Compact Flash Specification Ver. 1.4.

### 8.1 SL11RIDE Pin Translation: 36-Pin—40-Pin Signals

Table 4 36-pin to 40-pin interface signals.

SL11RIDE Signal	36-Pin Signal	36-Pin	Translates	40-Pin
GND	GND	1	→	2
RESET	RESET	2	→	1
D8	D8	3	→	4
D7	D7	4	→	3
D9	D9	5	→	6
D6	D6	6	→	5
D10	D10	7	→	8
D5	D5	8	→	7
D11	D11	9	→	10
D4	D4	10	→	9
D12	D12	11	→	12
D3	D3	12	→	11
D13	D13	13	→	14
D2	D2	14	→	13
D14	D14	15	→	16
D1	D1	16	→	15
D15	D15	17	→	18
D0	D0	18	→	35
See note <sup>1</sup>	DMARQ	19		NC
nWR-- See note <sup>2</sup>	IOWR	20	→	23
nRD-- See note <sup>2</sup>	IORD	21	→	25
See note <sup>1</sup>	IORDY	22	→	27
See note <sup>1</sup>	DMACK	23		NC
INTRQ	IRQ	24	→	31
See note <sup>1</sup>	IOCS16	25	→	32
A1	A1	26	→	33
GND	GND	27	→	19
A0	A0	28	→	35
A2	A2	29	→	36
CS0 -- See note <sup>2</sup>	CS0	30	→	37
CS1-- See note <sup>1</sup>	CS1	31	→	38
GND	GND	32	→	22
VCC	+5V	33		VCC
GND	GND	34	→	24
VCC	+5V	35	→	VCC
GND	GND	36	→	26

**Note:**

1. These signals need 5.6k ohms pull up.
2. Requires RC Termination.

**8.2 SL11RIDE Pin Translation: 40-Pin—44-Pin Signals****Table 5** SL11RIDE Pin Translation: 40-Pin—44-Pin Signals

IDE Signal	Pin	Pin	IDE Signal
	A	B	(See note)
	C	D	(See note)
	E	F	(See note)
RESET	1	2	GND
DD7	3	4	DD8
DD6	5	6	DD9
DD5	7	8	DD10
DD4	9	10	DD11
DD3	11	12	DD12
DD2	13	14	DD13
DD1	15	16	DD14
DD0	17	18	DD15
GND	19	20	Key-- See note <sup>1</sup>
DMARQ-- See note <sup>4</sup>	21	22	GND
DIOW-- See note <sup>3</sup>	23	24	GND
DIOR-- See note <sup>3</sup>	25	26	GND
IORDY	27	28	CSEL-- See note <sup>2</sup>
DMACK See note <sup>4</sup>	29	30	GND
INTRQ	31	32	IOCS16-- See note <sup>4</sup>
DA1	33	34	PDIAG-- See note <sup>4</sup>
DA0	35	36	DA2
CS0-- See note <sup>3</sup>	37	38	CS1-- See note <sup>4</sup>
DASP	39	40	GND
+5V	41	42	+5V
GND	43	44	TYPE

**Note:** A—F: Pins that are additional to those of the 40-pin connector.

1. The Key pin must be not connected
2. CSEL connect to GND for default Cable select and Master modes
3. Requires RC Termination
4. These signals need 5.6k pull up

### 8.3 SL11RIDE Pin Translation: 40-Pin—50-Pin CF Card Signals

Table 6 SL11RIDE Pin Translation: 40-Pin—50-Pin Signals

SL11RIDE Signals	CF Signals	Pin	Pin	CF Signals	SL11RIDE Signals
GND	GND	1	2	D3	D3
D4	D4	3	4	D5	D5
D6	D6	5	6	D7	D7
CS0-- See Note <sup>3</sup>	CE1	7	8	A10	NC
GND	OE	9	10	A9	NC
NC	A8	11	12	A7	NC
VCC-- See Note <sup>4</sup>	VCC	13	14	A6	NC
NC	A5	15	16	A4	NC
NC	A3	17	18	A2	A2
A1	A1	19	20	A0	A0
D0	D0	21	22	D1	D1
D2	D2	23	24	IOSI16	See Note <sup>1</sup>
NC	CD2	25	26	CD1	C_DET (Card Detect)
D11	D11	27	28	D12	D12
D13	D13	29	30	D14	D14
D15	D15	31	32	CE2	CS1
GND	VS1	33	34	IORD	nRD- See Note <sup>3</sup>
nWR-- See Note <sup>3</sup>	IOWR	35	36	WE	VCC See Note <sup>4</sup>
INTRQ	IREQ	37	38	VCC	VCC See Note <sup>4</sup>
GND-- See Note <sup>2</sup>	CSEL	39	40	VS2	NC
RESET	RESET	41	42	WAIT	See Note <sup>1</sup>
NC	INPACK	43	44	REG	See Note <sup>1</sup>
See Note <sup>1</sup>	BVD2	45	46	BVD1	See Note <sup>1</sup>
D8	D8	47	48	D9	D9
D10	D10	49	50	GND	GND

**Note:**

1. These signals need 5.6k ohms pull up.
2. CSEL connect to GND for default Cable select and Master modes
3. Required RC Termination.
4. VCC= 5VDC from either external source or from USB source.

## 8.4 SL11RIDE Pin Translation: 40-Pin—50-Pin SLIM Connector

The SLIM connector is a new connector that uses for CD-ROM, CD-RW, and ZIP drives.

**Table 7** SL11RIDE Pin Translation: 40-Pin—50-Pin SLIM Signals

SL11RIDE Signals	SLIM Signals	Pin	Pin	SLIM Signals	SL11RIDE Signals
NC	LOUT	1	2	ROUT	NC
GND	AGND	3	4	NC	NC
RESET	RESET	5	6	DD8	D8
D7	DD7	7	8	DD9	D9
D6	DD6	9	10	DD10	D10
D5	DD5	11	12	DD11	D11
D4	DD4	13	14	DD12	D12
D3	DD3	15	16	DD13	D13
D2	DD2	17	18	DD14	D14
D1	DD1	19	20	DD15	D15
D0	DD0	21	22	DMARQ	See Note <sup>1</sup>
GND	GND	23	24	DIOR-	nRD--- See Note <sup>3</sup>
nWR-- See Note <sup>3</sup>	DIOW	25	26	GND	GND
See Note <sup>1</sup>	IORDY	27	28	DMACK	See Note <sup>1</sup>
INTRQ	INTRQ	29	30	IOCS16	See Note <sup>1</sup>
A1	DA1	31	32	PDIAG	See Note <sup>1</sup>
A0	DA0	33	34	DA2	A2
CS0--- See Note <sup>3</sup>	CS0	35	36	CS1-	CS1
DASP	DASP	37	38	VCC	VCC--- See Note <sup>4</sup>
VCC--- See Note <sup>4</sup>	VCC	39	40	VCC	VCC--- See Note <sup>4</sup>
VCC--- See Note <sup>4</sup>	VCC	41	42	VCC	VCC--- See Note <sup>4</sup>
GND	GND	43	44	GND	GND
GND	GND	45	46	GND	GND
CSEL See Note <sup>2</sup>	CSEL	47	48	GND	GND
NC	Reserved	49	50	Reserved	NC

**Note:**

1. These signals need 5.6k ohms pull up.
2. CSEL connect to GND for Cable select to Master mode
3. Required RC Termination.
4. VCC= 5VDC from either external source or from USB source.