

用于双路SCART连接器的音频/视频开关

概述

MAX4397双路SCART开关矩阵可以在I²C*总线的控制下，为MPEG编码器与两路外部SCART连接器之间提供音频和视频信号切换，符合EN50049-1、IEC 933-1、Canal+以及BSkyB标准。

视频和音频通道均包括输入信号源选择复用器、输入缓冲器和输出缓冲器，可切换所有输入至选择的输出端。MAX4397D音频编码器输入采用差分DC耦合，而MAX4397S音频编码器输入采用单端AC耦合。除了MAX4397D音频编码器输入之外，所有其它输入和输出均采用AC耦合，内部DC偏置设置为预定值。

MAX4397可为红、绿、蓝分量视频信号提供+5dB至+7dB的可编程增益控制，步长为1dB。所有其它视频输出具有+6dB固定增益。此外，器件还包含内部亮度与色度(Y/C)混频器，可生成复合视频信号(CVBS)以驱动RF调制器输出，还具有截止频率为6MHz的内部视频重建低通滤波器。MAX4397的TV音频通道可实现无杂音切换，并具有-56dB至+6dB、步长2dB的可编程音量控制。VCR音频输出增益可编程设定为-6dB、0dB或+6dB。器件也可由左右声道的立体声输入生成单声道音频信号。所有音频驱动器可提供最小3.0V_{RMS}输出。

MAX4397工作于标准5V和12V电源，支持低速和快速信号切换。可通过I²C接口对增益和音量进行编程设置，并选择输入信号源进行切换。

MAX4397采用紧凑的48引脚薄型QFN封装，工作于0°C至+70°C商业级温度范围。

应用

卫星机顶盒
线缆机顶盒
TV
VCR
DVD

特性

- ◆ 驱动150Ω负载时，视频输出2V_{P-P}
- ◆ 驱动10kΩ负载时，音频输出3V_{RMS}
- ◆ 无杂音音频增益控制与切换
- ◆ 带内部箝位和偏置电路的AC耦合视频输入
- ◆ DC耦合视频输出
- ◆ Y/C输入在内部生成复合视频信号
- ◆ 内部视频重建滤波器在27MHz时提供-35dB衰减
- ◆ 差分(MAX4397D)或单端(MAX4397S)音频编码器输入
- ◆ 红色/色度开关，实现双向I/O
- ◆ RGB增益可通过I²C接口编程设置为+5dB至+7dB
- ◆ 音频增益控制可通过I²C接口编程设置为+6dB至-56dB
- ◆ 符合EN50049-1、IEC 933-1、Canal+以及BSkyB规范

订购信息

PART	TEMP RANGE	PIN-PACKAGE
MAX4397DCTM	0°C to +70°C	48 Thin QFN-EP* (7mm x 7mm)
MAX4397SCTM	0°C to +70°C	48 Thin QFN-EP* (7mm x 7mm)

*EP = 裸露焊盘。

引脚配置和典型应用电路在数据资料的最后部分给出。

系统框图在数据资料的最后部分给出。

*购买Maxim Integrated Products, Inc.或其从属授权关联公司的I²C产品，即得到了Philips I²C的专利许可，将这些产品用于符合Philips定义的I²C标准规范的系统。

用于双路SCART连接器的音频/视频开关

ABSOLUTE MAXIMUM RATINGS

V _{VID} to GNDVID.....	-0.3V to +6V	All Video Outputs, TVOUT_FS to V _{VID} , V _{AUD} , GNDAUD, GNDVID.....	Continuous
V ₁₂ to GNDAUD.....	-0.3V to +14V	All Audio Outputs to V _{VID} , V _{AUD} , V ₁₂ , GNDVID, GNDAUD.....	Continuous
V _{AUD} to GNDAUD.....	-0.3V to +6V	Continuous Power Dissipation (T _A = +70°C) 48-Pin Thin QFN (derate 27mW/°C above +70°C).....	2105.3mW
GNDAUD to GNDVID.....	-0.1V to +0.1V	Operating Temperature Range.....	0°C to +70°C
All Video Inputs, ENCIN_FS, VCRIN_FS, SET to GNDVID.....	-0.3V to (V _{VID} + 0.3V)	Junction Temperature.....	+150°C
All Audio Inputs, AUDBIAS to GNDAUD.....	-0.3V to (V _{AUD} + 0.3V)	Storage Temperature Range.....	-65°C to +150°C
SDA, SCL, DEV_ADDR to GNDVID.....	-0.3V to +6V	Lead Temperature (soldering, 10s).....	+300°C
All Audio Outputs, TV_SS, VCR_SS to GNDAUD.....	-0.3V to (V ₁₂ + 0.3V)		

Stresses beyond those listed under "Absolute Maximum Ratings" may cause permanent damage to the device. These are stress ratings only, and functional operation of the device at these or any other conditions beyond those indicated in the operational sections of the specifications is not implied. Exposure to absolute maximum rating conditions for extended periods may affect device reliability.

ELECTRICAL CHARACTERISTICS

(V₁₂ = 12V, V_{VID} = V_{AUD} = 5V, 0.1μF X5R capacitor in parallel with a 10μF aluminum electrolytic capacitor from V_{AUD} to GNDAUD, V₁₂ to GNDAUD, and V_{VID} to GNDVID, SET = 100kΩ nominal, R_{LOAD} = 150Ω, T_A = 0°C to +70°C, unless otherwise noted. Typical values are at T_A = +25°C.) (Note 1)

PARAMETER	SYMBOL	CONDITIONS	MIN	TYP	MAX	UNITS
V _{VID} Supply Voltage Range	V _{VID}	Inferred from video gain test at 4.75V and 5.2V	4.75	5.0	5.25	V
V _{AUD} Supply Voltage Range	V _{AUD}	Inferred from audio gain test at 4.75V and 5.2V	4.75	5.0	5.25	V
V ₁₂ Supply Voltage Range	V ₁₂	Inferred from slow switching levels	11.4	12.0	12.6	V
V _{VID} Quiescent Supply Current	I _{VID_Q}	All video output amplifiers are enabled, no load		69	100	mA
V _{VID} Standby Supply Current	I _{VID_S}	All video output amplifiers are in shutdown, and TV_FS_OUT driver is in shutdown, no load		40	60	mA
V _{AUD} Quiescent Supply Current	I _{AUD_Q}	No load		2.4	6	mA
V ₁₂ Quiescent Supply Current	I _{12_Q}	No load		3.6	6	mA
VIDEO CHARACTERISTICS						
Voltage Gain	G _V	CVBS and Y-C, 1V _{p-p} input	+5.5	+6.0	+6.5	dB
		R,G,B, 1V _{p-p} input, (programmable gain control)	+4.5	+5.0	+5.5	
			+5.5	+6.0	+6.5	
			+6.5	+7.0	+7.5	
LP Filter Attenuation	ATTN	T _A = +25°C, f = 6MHz, V _{IN} = 1V _{p-p}		1.2	3.3	dB
LP Filter Suppression	SPPR	T _A = +25°C, f = 27MHz, V _{IN} = 1V _{p-p}	35	50		dB
Slew Rate	SR	V _{OUT} = 2V _{p-p}		8		V/μs
Settling Time	t _S	V _{OUT} = 2V _{p-p} , settle to 0.1% (Note 2)		380		ns
Gain Matching	AG	1V _{p-p} input, between RGB or Y-C	-0.5		+0.5	dB
Differential Gain	DG	5-step modulated staircase		0.4		%
Differential Phase	DP	5-step modulated staircase		0.2		degrees
Signal-to-RMS Noise	SNR _V	V _{IN} = 1V _{p-p}		65		dB

用于双路SCART连接器的音频/视频开关

MAX4397

ELECTRICAL CHARACTERISTICS (continued)

($V_{12} = 12V$, $V_{VID} = V_{AUD} = 5V$, $0.1\mu F$ X5R capacitor in parallel with a $10\mu F$ aluminum electrolytic capacitor from V_{AUD} to GND_{AUD} , V_{12} to GND_{AUD} , and V_{VID} to GND_{VID} , $SET = 100k\Omega$ nominal, $R_{LOAD} = 150\Omega$, $T_A = 0^\circ C$ to $+70^\circ C$, unless otherwise noted. Typical values are at $T_A = +25^\circ C$.) (Note 1)

PARAMETER	SYMBOL	CONDITIONS	MIN	TYP	MAX	UNITS
Group Delay Variation	ΔGD	$f = 0.1MHz$ to $4.43MHz$		14		nS
Sync-Tip Clamp Level	V_{CLMP}	RGB, Composite, and Luma input, no signal, no load		1.21		V
Chroma Bias	V_{BIAS}	Chroma input only, no signal, no load		1.9		V
Droop	D	Set by input current	-2		+2	%
Power-Supply Rejection Ratio	PSRR_V	DC, $0.5V_{P-P}$		48		dB
Input Impedance	Z_{IN}	CVBS, Y, or RGB video inputs, $V_{IN} > V_{CLMP}$		4		$M\Omega$
		Chroma video input, $V_{IN} = V_{BIAS}$		11		$k\Omega$
Input Clamp Current	I_{CLMP}	$V_{IN} = 1.75V$	2.5	5	8.0	μA
Pulldown Resistance	RP	Enable VCR_R/C_OUT and TV_R/C_OUT pulldown through I ² C, (see registers 7 and 9 for loading register details)		10		Ω
Output Pin Bias Voltage	V_{OUT}	RGB, Composite, and Luma, no signal, no load		1.08		V
		Chroma, no signal, no load		2.27		
Crosstalk	XTLK	Between any two active inputs, $f = 4.43MHz$, $V_{IN} = 1V_{P-P}$		-50		dB
Mute Suppression	M_{SPR_V}	$f = 4.43MHz$, $V_{IN} = 1V_{P-P}$, on one input only		-50		dB
AUDIO CHARACTERISTICS (Note 3)						
Voltage Gain (From Application Input)	G_A	TV or VCR to stereo, gain = 0dB, $V_{IN} = 1V_{P-P}$	-0.5	0	+0.5	dB
		TV or VCR to mono, gain = 0dB, $V_{IN} = 1V_{P-P}$	2.5	3	3.5	
		ENC to stereo, gain = 0dB, $V_{IN} = 1V_{P-P}$	3.02	3.52	4.02	
		ENC to mono, gain = 0dB, $V_{IN} = 1V_{P-P}$	6.02	6.52	7.02	
Gain Matching Between Channels	ΔG_A	Gain = 0dB, $V_{IN} = 1V_{P-P}$	-0.5	0	+0.5	dB
Flatness	ΔA	$f = 20Hz$ to $20kHz$, $0.5V_{RMS}$ input, gain = 0dB		0.01		dB
Frequency Bandwidth	BW	$0.5V_{RMS}$ input, frequency where output is -3dB referenced to 1kHz		230		kHz
Input DC Level (Excluding Encoder Inputs that are High Impedance)	V_{IN}	Gain = 0dB		$0.2308 \times V_{12}$		V
Encoder Input Common-Mode Voltage Range	V_{CM}	MAX4397D only, input differential signal = 0V	1.2		$V_{AUD} - 0.7$	V

用于双路SCART连接器的音频/视频开关

MAX4397

ELECTRICAL CHARACTERISTICS (continued)

($V_{12} = 12V$, $V_{VID} = V_{AUD} = 5V$, 0.1 μF X5R capacitor in parallel with a 10 μF aluminum electrolytic capacitor from V_{AUD} to GND_{AUD} , V_{12} to GND_{AUD} , and V_{VID} to GND_{VID} , $SET = 100k\Omega$ nominal, $R_{LOAD} = 150\Omega$, $T_A = 0^\circ C$ to $+70^\circ C$, unless otherwise noted. Typical values are at $T_A = +25^\circ C$.) (Note 1)

PARAMETER	SYMBOL	CONDITIONS	MIN	TYP	MAX	UNITS
Encoder Common-Mode Rejection Ratio	CMRR	MAX4397D only, over V_{CM} range		40		dB
Input Signal Amplitude	V_{IN_AC}	Single-ended inputs, $f = 1kHz$, THD < 1%		3		V_{RMS}
		ENC inputs differential level, MAX4397D, $f = 1kHz$, THD < 1%		2.08		
		ENC inputs single-ended, MAX4397S, $f = 1kHz$, THD < 1%		1.31		
Input Resistance (Measured at Parts Input)	R_{IN}	Single ended: VCR_INR, VCR_INL, TV_INR, TV_INL		0.1		M Ω
		Encoder, MAX4397D: ENC_INL+, ENC_INL-, ENC_INR+, ENC_INR-		1		
		Encoder, MAX4397S: ENC_INL, ENC_INR		0.1		
Output DC Level	V_{OUT_DC}	$V_{IN} = 0V$		0.5 x V_{12}		V
Signal-to-Noise Ratio	SNR_A	$f = 1.0kHz$, 1 V_{RMS} application input, gain = 0dB, 20Hz to 20kHz		95		dB
Total Harmonic Distortion Plus Noise	THD+N	$R_{LOAD} = 10k\Omega$, $f = 1.0kHz$, 0.5 V_{RMS} output		0.004		%
		$R_{LOAD} = 10k\Omega$, $f = 1.0kHz$, 2 V_{RMS} output		0.004		
Output Impedance	ZO	$f = 1kHz$		1		Ω
Volume Attenuation Step	ASTEPA	1.414 V_{P-P} input, programmable gain to TV SCART volume control range extends from -56dB to +6dB	1.5	2	2.5	dB
		1.414 V_{P-P} input, programmable gain to VCR audio extends from -6dB to +6dB	5.5	6	6.5	
Power-Supply Rejection Ratio	PSRR_A	From V_{12} , $f = 1kHz$, 0.5 V_{P-P} , ($C_{AUD_BIAS} = 47\mu F$), gain = 0dB		75		dB
		From V_{AUD} , $f = 1kHz$, 0.5 V_{P-P} , $V_{AUD} \geq +4.75V$, $V_{AUD} \leq +5.25V$, gain = 0dB		75		
Mute Suppression	M_SPR_A	$f = 1kHz$, 0.5 V_{RMS} input, set through I ² C, see register 1 for loading register details		90		dB
Audio Clipping Level	VCLIP	$f = 1kHz$, 2.5 V_{RMS} input, gain = 6dB, THD < 1%		3.6		V_{RMS}
Left-to-Right Crosstalk	XTLK_LR	$f = 1kHz$, 0.5 V_{RMS} input, gain = 0dB		80		dB
Crosstalk	XTLK_CC	TV SCART to VCR SCART or VCR SCART to TV SCART, $f = 1kHz$, 0.5 V_{RMS} input, gain = 0dB		90		dB

用于双路SCART连接器的音频/视频开关

MAX4397

ELECTRICAL CHARACTERISTICS (continued)

($V_{12} = 12V$, $V_{VID} = V_{AUD} = 5V$, $0.1\mu F$ X5R capacitor in parallel with a $10\mu F$ aluminum electrolytic capacitor from V_{AUD} to GND_{AUD} , V_{12} to GND_{AUD} , and V_{VID} to GND_{VID} , $SET = 100k\Omega$ nominal, $R_{LOAD} = 150\Omega$, $T_A = 0^\circ C$ to $+70^\circ C$, unless otherwise noted. Typical values are at $T_A = +25^\circ C$.) (Note 1)

PARAMETER	SYMBOL	CONDITIONS	MIN	TYP	MAX	UNITS
DIGITAL INTERFACE: SDA AND SCL (Note 5)						
Low-Level Input Voltage	V_{IL}		0		0.8	V
High-Level Input Voltage	V_{IH}		2.6			V
Hysteresis of Schmitt Trigger Input				0.2		V
SDA Low-Level Output Voltage	V_{OL}	$I_{SINK} = 3mA$			0.4	V
		$I_{SINK} = 6mA$			0.6	
Output Fall Time for SDA Line		400pF bus load			250	ns
Spike Suppression				50		ns
Input Current			-10		+10	μA
Input Capacitance				5		pF
SCL Clock Frequency			0		400	kHz
Hold Time	$t_{HD,STA}$		0.6			μs
Low Period of SCL Clock	t_{LOW}		1.3			μs
High Period of SCL Clock	t_{HIGH}		0.6			μs
Setup Time for a Repeated Start Condition	$t_{SU,STA}$		0.6			μs
Data Hold Time	$t_{HD,DAT}$		0		0.9	μs
Data Setup Time	$t_{SU,DAT}$		100			ns
Setup Time for Stop Condition	$t_{SU,STO}$		0.6			μs
Bus Free Time Between a Stop and Start	t_{BUF}		1.3			μs
OTHER DIGITAL PINS (Note 5)						
DEV_ADDR Low Level					0.8	V
DEV_ADDR High Level			2.6			V
SLOW SWITCHING SECTION (Note 5)						
Input Low Level			0		2	V
Input Medium Level			4.5		7.0	V
Input High Level			9.5		V_{12}	V
Input Current				50	100	μA
Output Low Level		10k Ω to ground, internal TV, $11.4V < V_{12} < 12.6V$	0		1.5	V
Output Medium Level		10k Ω to ground, external 16/9, $11.4V < V_{12} < 12.6V$	5.0		6.5	V
Output High Level		10k Ω to ground, external 4/3, $11.4V < V_{12} < 12.6V$	10		V_{12}	V

用于双路SCART连接器的音频/视频开关

ELECTRICAL CHARACTERISTICS (continued)

($V_{I2} = 12V$, $V_{VID} = V_{AUD} = 5V$, $0.1\mu F$ X5R capacitor in parallel with a $10\mu F$ aluminum electrolytic capacitor from V_{AUD} to GND_{AUD} , V_{I2} to GND_{AUD} , and V_{VID} to GND_{VID} , $SET = 100k\Omega$ nominal, $R_{LOAD} = 150\Omega$, $T_A = 0^\circ C$ to $+70^\circ C$, unless otherwise noted. Typical values are at $T_A = +25^\circ C$.) (Note 1)

PARAMETER	SYMBOL	CONDITIONS	MIN	TYP	MAX	UNIT
FAST SWITCHING SECTION (Note 5)						
Input Low Level			0		0.4	V
Input High Level			1		3	V
Input Current				1	10	μA
Output Low Level		$I_{SINK} = 0.5mA$	0	0.01	0.2	V
Output High Level		$I_{SOURCE} = 20mA$, $V_{VID} - V_{OH}$		0.75	2	V
Fast Switching Output to RGB Skew		(Note 4)		30		ns
Fast Switching Output Rise Time		150Ω to ground		30		ns
Fast Switching Output Fall Time		150Ω to ground		30		ns

Note 1: All devices are 100% tested at $T_A = +25^\circ C$. All temperature limits are guaranteed by design.

Note 2: The settling time is measured from the 50% of the input swing to the 0.1% of the final value of the output.

Note 3: Maximum load capacitance is $200pF$. All the listed parameters are measured at application's inputs, unless otherwise noted. See the *Typical Application Circuits*.

Note 4: Difference in propagation delays of fast-blanking signal and RGB signals. Measured from 50% input transition to 50% output transition. Signal levels to be determined.

Note 5: Guaranteed by design.

典型工作特性

($V_{I2} = 12V$, $V_{VID} = V_{AUD} = 5V$, $0.1\mu F$ X5R capacitor in parallel with a $10\mu F$ aluminum electrolytic capacitor from V_{AUD} to GND_{AUD} , V_{I2} to GND_{AUD} , V_{VID} to GND_{VID} no load, $T_A = 0^\circ C$ to $+70^\circ C$, unless otherwise noted. Typical values are at $T_A = +25^\circ C$.)

R/G/B VIDEO LARGE-SIGNAL BANDWIDTH vs. FREQUENCY

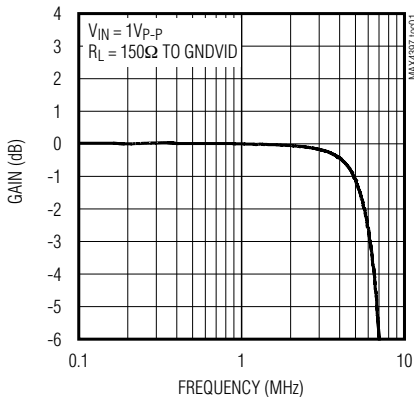

GROUP DELAY vs. FREQUENCY

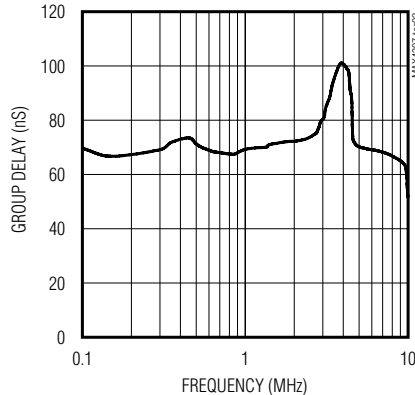

Y VIDEO LARGE-SIGNAL BANDWIDTH vs. FREQUENCY

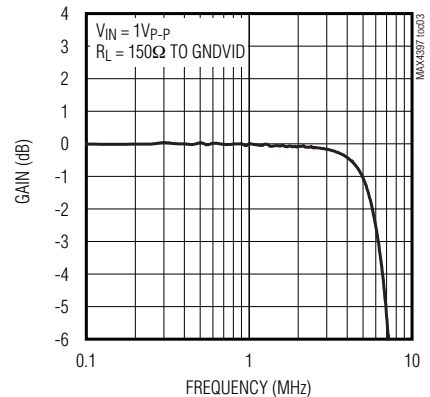

用于双路SCART连接器的音频/视频开关

典型工作特性 (续)

($V_{I2} = 12V$, $V_{VID} = V_{AUD} = 5V$, $0.1\mu F$ X5R capacitor in parallel with a $10\mu F$ aluminum electrolytic capacitor from V_{AUD} to GND_{AUD} , V_{I2} to GND_{AUD} , V_{VID} to GND_{VID} no load, $T_A = 0^\circ C$ to $+70^\circ C$, unless otherwise noted. Typical values are at $T_A = +25^\circ C$.)

MAX4397

R/G/B VIDEO SMALL-SIGNAL BANDWIDTH vs. FREQUENCY

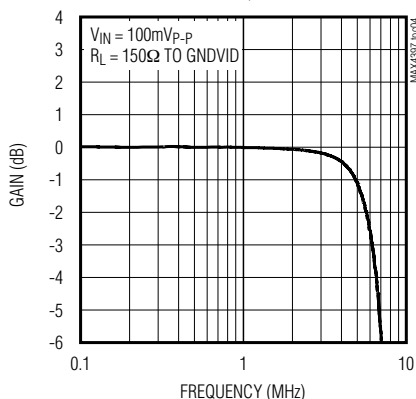

Y VIDEO SMALL-SIGNAL BANDWIDTH vs. FREQUENCY

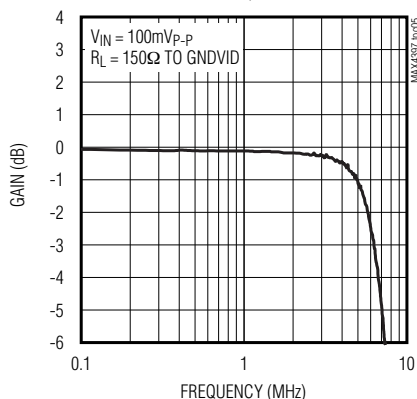

VIDEO CROSSTALK vs. FREQUENCY

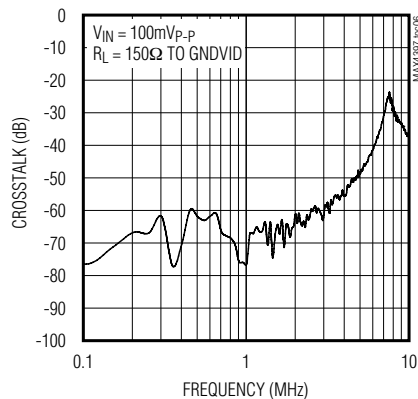

AUDIO LARGE-SIGNAL BANDWIDTH vs. FREQUENCY

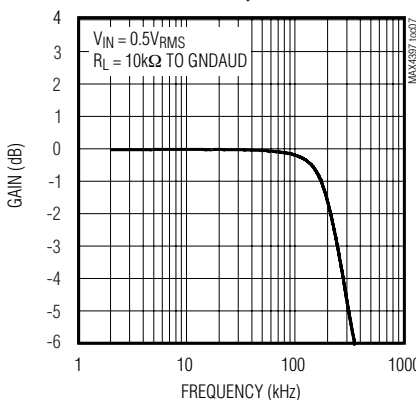

AUDIO CROSSTALK vs. FREQUENCY

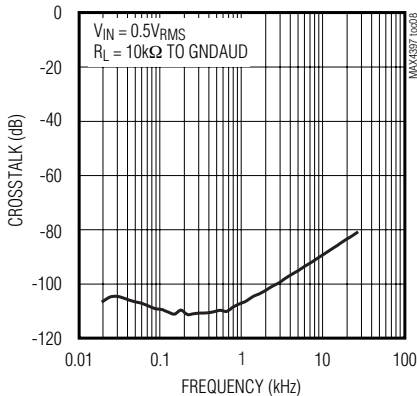

AUDIO TOTAL HARMONIC DISTORTION PLUS NOISE vs. FREQUENCY

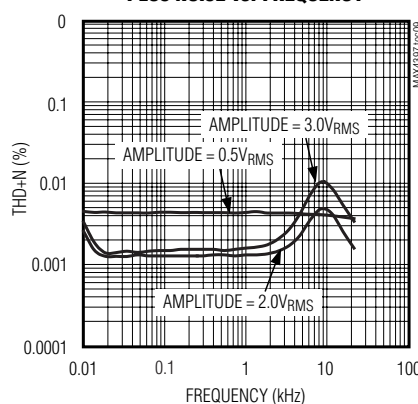

POWER-SUPPLY REJECTION RATIO vs. FREQUENCY

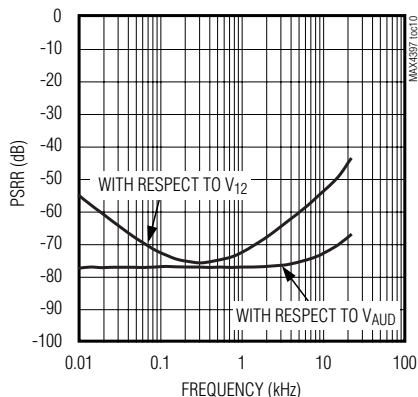

V_{VID} QUIESCENT SUPPLY CURRENT vs. TEMPERATURE

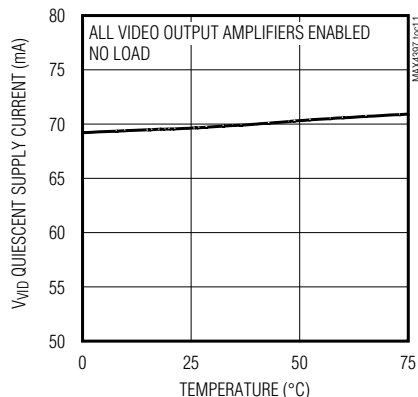

用于双路SCART连接器的音频/视频开关

典型工作特性 (续)

($V_{12} = 12V$, $V_{VID} = V_{AUD} = 5V$, $0.1\mu F$ X5R capacitor in parallel with a $10\mu F$ aluminum electrolytic capacitor from V_{AUD} to GND_{AUD} , V_{12} to GND_{AUD} , V_{VID} to GND_{VID} no load, $T_A = 0^\circ C$ to $+70^\circ C$, unless otherwise noted. Typical values are at $T_A = +25^\circ C$.)

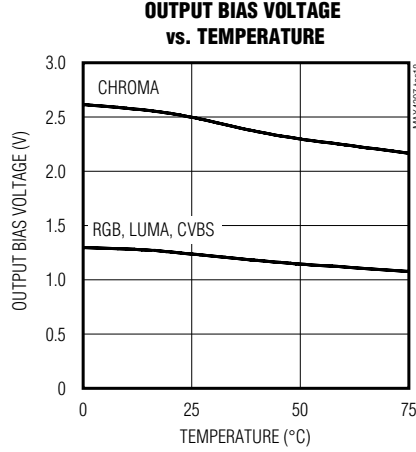
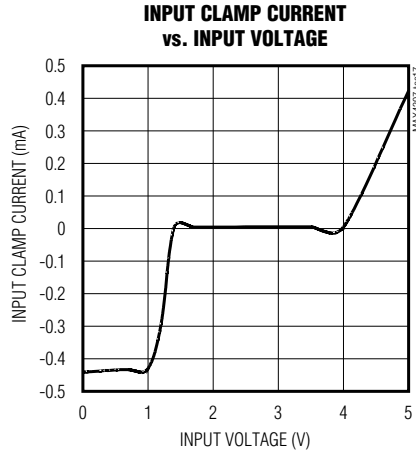
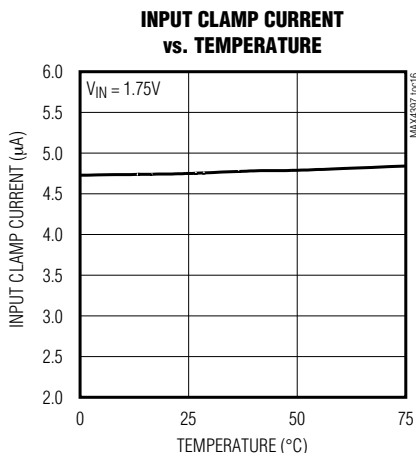
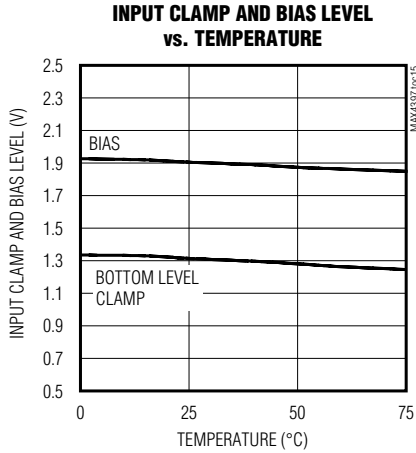
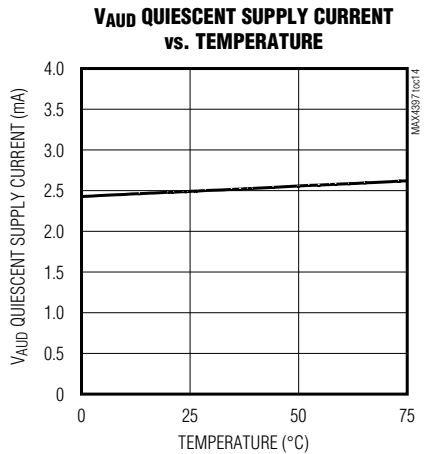
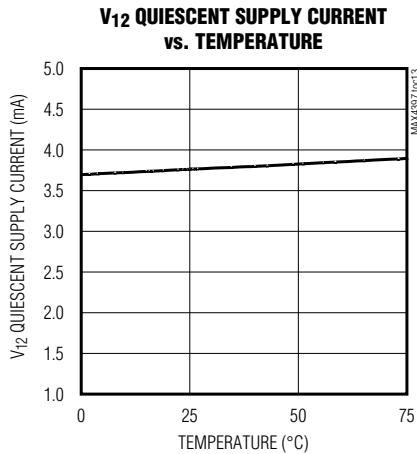
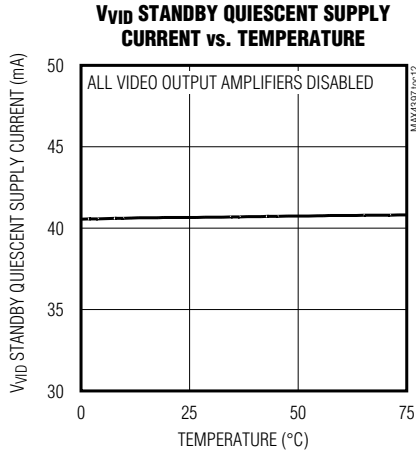

用于双路SCART连接器的音频/视频开关

引脚说明

MAX4397

引脚		名称	功能
MAX4397D	MAX4397S		
1	1	SDA	双向数据I/O。I ² C兼容、2线接口数据输入/输出。输出为漏极开路。
2	2	SCL	串行时钟输入。I ² C兼容、2线时钟接口。
3	3	DEV_ADDR	器件地址设置输入。连接至GNDVID可将写地址和读地址分别设置为94h和95h；连接至V _{VID} 将写地址和读地址分别设置为96h和97h。
4	—	ENC_INL+	数字编码器左声道音频输入正端。
—	4	ENC_INL	数字编码器左声道音频输入。
5	—	ENC_INL-	数字编码器左声道音频输入负端。
—	5, 7	N.C.	不连接，内部未连接。
6	—	ENC_INR+	数字编码器右声道音频输入正端。
—	6	ENC_INR	数字编码器右声道音频输入。
7	—	ENC_INR-	数字编码器右声道音频输入负端。
8	8	VCR_INR	VCR SCART右声道音频输入。
9	9	VCR_INL	VCR SCART左声道音频输入。
10	10	TV_INR	TV SCART右声道音频输入。
11	11	TV_INL	TV SCART左声道音频输入。
12	12	GNDAUD	音频地。
13	13	AUD_BIAS	音频输入偏置电压。用一个47μF电容和一个0.1μF电容旁路AUD_BIAS至GNDAUD。
14	14	V _{AUD}	音频电源。接+5V电源。用并联的10μF铝电解电容与0.47μF低ESR陶瓷电容旁路至GNDAUD。
15	15	VCR_OUTR	VCR SCART右声道音频输出。
16	16	VCR_OUTL	VCR SCART左声道音频输出。
17	17	RF_MONO_OUT	RF调制器单声道音频输出。
18	18	TV_OUTL	TV SCART左声道音频输出。
19	19	TV_OUTR	TV SCART右声道音频输出。
20	20	V ₁₂	+12V电源。用并联的10μF电容与0.1μF电容旁路V ₁₂ 至地。
21	21	TV_SS	TV SCART双向低速切换信号。
22	22	VCR_SS	VCR SCART双向低速切换信号。
23	23	SET	滤波器截止频率设置输入端。SET与地之间接100kΩ电阻。
24, 36	24, 36	V _{VID}	视频和数字电源。接+5V电源。用一个0.01μF电容旁路至GNDVID。V _{VID} 同时作为I ² C接口的数字电源。
25	25	VCRIN_FS	VCR SCART快速切换输入。
26	26	ENCIN_FS	数字编码器快速切换输入。
27	27	TVOUT_FS	TV SCART快速切换输出。该信号用来将TV切换至RGB输入，以实现随屏显示功能。
28	28	GNDVID	视频地。

用于双路SCART连接器的音频/视频开关

引脚说明 (续)

引脚		名称	功能
MAX4397D	MAX4397S		
29	29	RF_CVBS_OUT	RF调制器复合视频信号输出。内部偏置为1V。
30	30	TV_Y/CVBS_OUT	TV SCART亮度/复合视频信号输出。内部偏置为1V。
31	31	TV_R/C_OUT	TV SCART红色/色度视频信号输出。红色视频信号时内部偏置为1V，色度视频信号时为2.2V。
32	32	TV_G_OUT	TV SCART绿色视频信号输出。内部偏置为1V。
33	33	TV_B_OUT	TV SCART蓝色视频信号输出。内部偏置为1V。
34	34	VCR_Y/CVBS_OUT	VCR SCART亮度/复合视频信号输出。内部偏置为1V。
35	35	VCR_R/C_OUT	VCR SCART红色/色度视频信号输出。红色视频信号时内部偏置为1V，色度视频信号时为2.2V。
37	37	TV_R/C_IN	TV SCART红色/色度视频信号输入。红色视频信号时内部偏置为1.2V，色度视频信号时为1.9V。
38	38	TV_Y/CVBS_IN	TV SCART亮度/复合视频信号输入。内部偏置为1.2V。
39	39	VCR_Y/CVBS_IN	VCR SCART亮度/复合视频信号输入。内部偏置为1.2V。
40	40	VCR_R/C_IN	VCR SCART红色/色度视频输入。红色视频信号时内部偏置为1.2V，色度视频信号时为1.9V。
41	41	VCR_G_IN	VCR SCART绿色视频信号输入。内部偏置为1.2V。
42	42	VCR_B_IN	VCR SCART蓝色视频信号输入。内部偏置为1.2V。
43	43	ENC_Y/CVBS_IN	数字编码器亮度/复合视频信号输入。内部偏置为1.2V。
44	44	ENC_R/C_IN	数字编码器红色/色度视频输入。红色视频信号时内部偏置为1.2V，色度视频信号时为1.9V。
45	45	ENC_G_IN	数字编码器绿色视频输入。内部偏置为1.2V。
46	46	ENC_B_IN	数字编码器蓝色视频输入。内部偏置为1.2V。
47	47	ENC_Y_IN	数字编码器亮度视频输入。内部偏置为1.2V。
48	48	ENC_C_IN	数字编码器色度视频输入。内部偏置为1.9V。
EP	EP	GNDAUD	裸露焊盘。焊接至电路板的地层 (GNDAUD)，以获得良好的散热和电气性能。

详细说明

MAX4397是一个开关矩阵，可通过I²C接口切换不同端口之间的音频和视频信号。此类端口包括MPEG解码器输出、TV SCART连接器和VCR SCART连接器。根据EN50049和IEC 933的规定，编码器只能把信号输入SCART连接器，而TV和VCR SCART连接器是双向的。

MAX4397电路由四个主要部分组成：视频部分、音频部分、低速和快速切换部分以及数字接口。

视频部分包括箝位和偏置电路、输入缓冲器、重建滤波器、开关矩阵、Y/C混频器和输出缓冲器。所有视频输入均通过0.1μF电容实现AC耦合，从而可通过箝位或偏置网络建立合适的DC电平。当红色/色度信号作为输入时，

可通过I²C控制将双向红色/色度输出接地以实现端接 (参见视频输入部分)。

音频部分包括输入缓冲器、开关矩阵、音量或增益控制电路以及输出驱动器。音频输入通过0.1μF电容实现AC耦合。MAX4397D和MAX4397S的区别仅仅在于音频编码器输入。MAX4397S的音频编码器输入是单端的，而MAX4397D的音频编码器输入是差分形式的。TV输出音频通道的音量控制范围为-56dB到+6dB，步长为2dB。VCR输出音频通道的音量控制范围为-6dB到+6dB，步长为6dB。可对MAX4397进行设置，在过零时切换输入，从而可降低杂音。

用于双路SCART连接器的音频/视频开关

低速切换功能使得引脚VCR_SS和TV_SS可以分别提供双向、三态、低速切换输入和输出信号。来自VCR的低速切换信号用来设定TV屏幕的宽高比或者视频信号源。参见低速切换部分。

快速切换包括两个分别来自编码器和VCR的输入，以及一个输出到TV的信号用于随屏显示 (OSD)。快速切换功能将来自VCR或者编码器的视频信号切换至TV。另外，快速切换输出可设置为高电平或低电平。快速切换通过I²C接口来控制。

数字模块部分包括2线接口电路、控制和状态寄存器。通过I²C兼容接口可对MAX4397进行配置。DEV_ADDR用来设置I²C兼容地址。

SCART 视频切换

MAX4397可切换MPEG解码器、TV SCART和VCR SCART间的视频信号。视频开关部分包括重建滤波器、多路复用视频放大器和驱动RF调制器所需的Y/C混频器。视频部分的功能框图见图1所示。由于SCART连接器支持RGB、S视频和复合视频格式，RGB和S视频通常共享一组双向的SCART连接器引脚。



图1. MAX4397视频部分功能框图

用于双路SCART连接器的音频/视频开关

视频输入

所有视频输入均采用AC耦合，外接 $0.1\mu\text{F}$ 电容。箝位电路或偏置电路用来建立视频信号的DC输入电平。箝位电路用来确定复合视频信号 (CVBS)、RGB分量或S视频亮度信号的同步头位置。如果该信号没有同步头，则箝位电路将信号最小值箝位到箝位电压上。偏置电路用来将S视频色度信号定位在亮度 (Y) 信号的中间值。在可以接收色度或红色视频信号的视频输入端，可通过I²C选择偏置电路或箝位电路。写寄存器的详细信息参见表3-12。

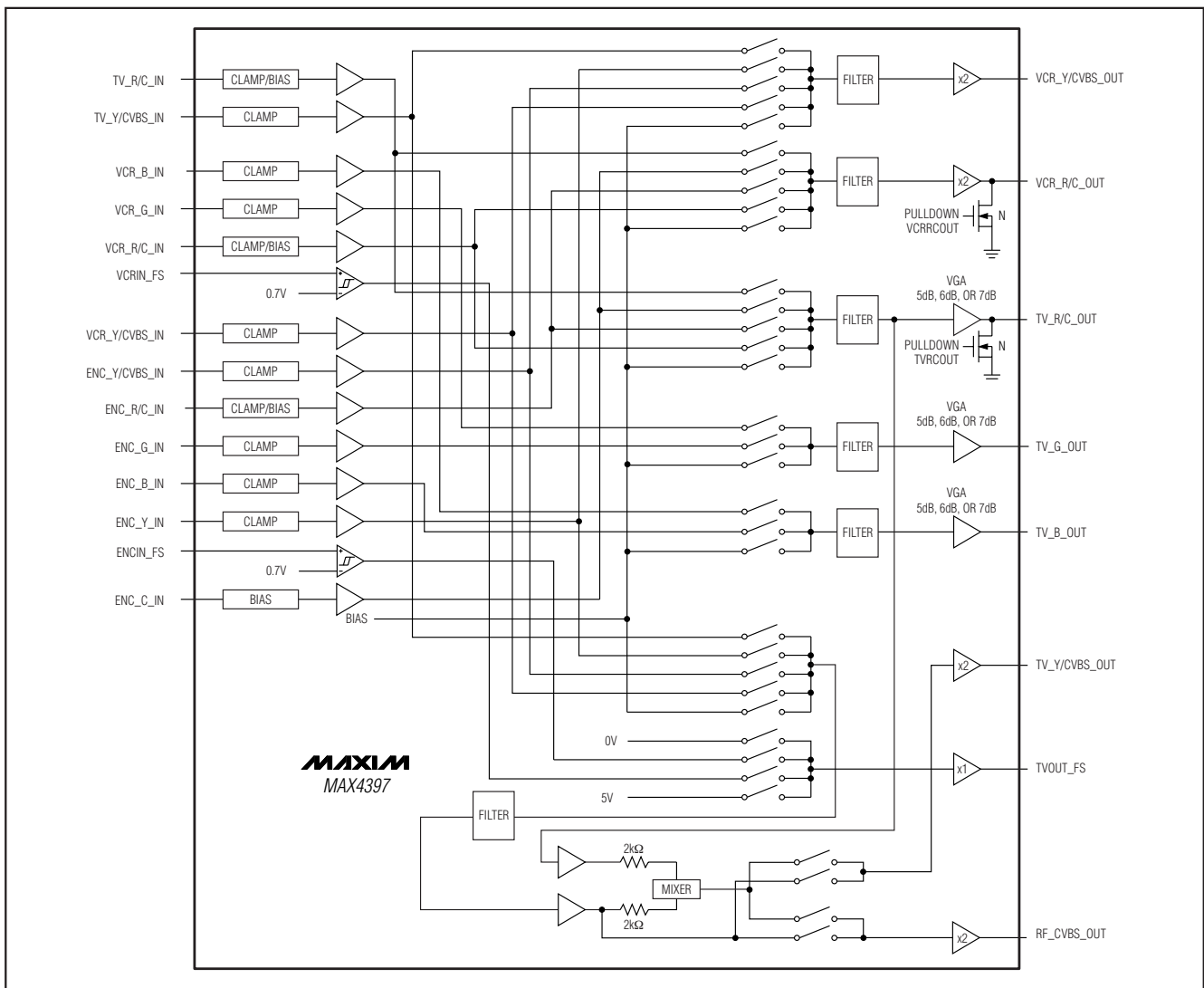
MPEG解码器和VCR使用RGB格式和快速切换功能以在TV上插入随屏显示 (OSD) 信息，通常是文本形式。MAX4397支持来自VCR或MPEG解码器的RGB作为输入，同时支持RGB作为输出切换至TV。RGB格式的红色视频信号和S-VHS格式的色度视频信号共享同一个SCART连接器引脚。因此，RGB和S视频信号不能同时存在。由于RGB SCART引脚既用于输入也用于输出，因此复合视频信号可实现环通接口，但RGB信号则不可以。

在SCART中，可能会用到红色/色度引脚的双向功能。当红色/色度引脚作为输入端口时，红色/色度输出通过一个

75Ω 电阻端接到地。因此，通过把红色/色度输出有源下拉到GNDVID可使该输出处于接地状态，从而可支持双向色度或红色信号I/O，并将输出源电阻变为端接电阻 (参见图2)。有源下拉也提供“静音输出”功能，从而禁用未选的视频输出。“静音输出”状态是视频部分上电时的缺省状态。

为了获得高品质的家用视频信号，MPEG解码器、VCR和TV均使用S视频格式。MAX4397支持来自VCR、MPEG解码器和TV的S视频信号作为输入，并支持其作为独立输出切换至TV和VCR。因为SCART连接器的早期规范不支持S视频信号，S视频的亮度 (Y) 信号和CVBS信号共享相同的SCART连接器引脚。如果存在S视频，那么必须由Y信号和C信号生成复合信号，以驱动RF_CVBS_OUT引脚。对于S视频来说，环通是不可能实现的，因为色度SCART端口既作为输入也作为输出。

MAX4397支持复合视频 (CVBS) 格式，输入来自VCR、MPEG解码器和TV。完全环通只适用于TV和VCR，因为针对CVBS格式，MPEG解码器SCART连接器有独立的输入和输出引脚。



图2. 双向SCART引脚

用于双路SCART连接器的音频/视频开关

视频输出

视频输出的DC电平是受控制的，因此不需要耦合电容，并且所有视频输出均可驱动DC耦合、150Ω、背向端接、以地为参考的同轴负载。由于一些电视和VCR使用行同步高度来实现自动增益控制，MAX4397可在±2%范围内精确重现同步高度。

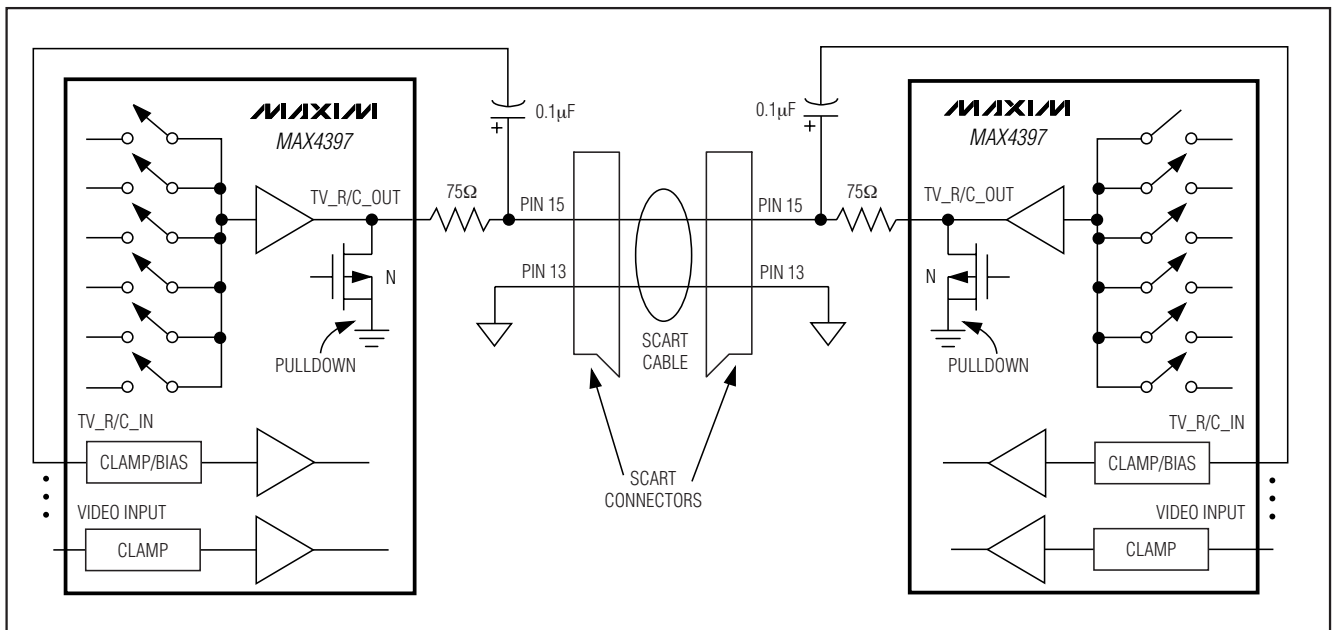
低速切换

MAX4397支持IEC 933-1, 修订版1 (Amendment 1), 三电平低速切换，用来选择显示器 (TV) 屏幕的宽高比。在I²C兼容接口的控制下，可对MAX4397低速切换的输出电压电平进行设置。表1给出了低速切换信号的有效输入电平和相应的显示器工作模式。

提供两个双向端口，用作TV和VCR的低速切换信号。连续读取低速切换输入状态并储存在寄存器0Eh内。通过写寄存器07h和09h，可将低速切换输出设置为逻辑电平或高阻抗。详细信息见表8和表10。

表 1. 低速切换模式

SLOW-SWITCHING SIGNAL VOLTAGE (V)	MODE
0 to 2	Display device uses an internal source such as a built-in tuner to provide a video signal
4.5 to 7.0	Display device uses a video signal from the SCART connector and sets the display to 16:9 aspect ratio
9.5 to 12.6	Display device uses a signal from the SCART connector and sets the display to 4:3 aspect ratio

快速切换

VCR或MPEG解码器向显示器或TV输出一个快速切换信号，以插入随屏显示 (OSD) 信息。也可通过I²C接口将快速切换信号设置为恒定高电平或低电平输出信号。通过写寄存器07h来设置快速切换输出。

Y/C混频器

MAX4397带有片上混频器，可由S视频 (Y和C) 生成复合视频 (CVBS) 信号。复合视频用来驱动RF_CVBS_OUT输出引脚。混频器电路将Y信号和C信号求和，以获得CVBS信号。一个+6dB输出缓冲器用来驱动RF_CVBS_OUT。

视频重建滤波器

编码器DAC输出需要低通滤波，以滤除带外噪声。MAX4397集成有重建滤波器。该滤波器是四阶的，由两个Sallen-Key双二阶滤波器级联而成，实现Butterworth传递函数。内部重建滤波器的截止频率为6MHz，27MHz时可最小衰减-35dB。注意，SET引脚用来设置滤波器截止频率的精度。SET与地之间接一只100kΩ电阻。

SCART音频切换

音频输入

MAX4397S的所有音频输入都采用单端AC耦合。除音频编码器输入采用差分DC耦合外，MAX4397D的音频输入也都采用单端AC耦合。

音频部分具有三个立体声音频输入，来自TV、VCR以及MPEG解码器SCART。每个输入都通过一个100kΩ电阻连接至内部生成的电压，其电压值为0.23 × V₁₂，MAX4397D的编码器输入例外，其DC偏置是通过外部设定的。

用于双路SCART连接器的音频/视频开关

音频输出

左右声道都有一个TV和VCR SCART立体声输出。单声道音频输出是由TV左、右声道混合生成的，用来驱动RF调制器，即RF_MONO_OUT。单声道混频器是一个电阻加法器，同时将两个信号的幅度均衰减6dB。单声道混频器之后是增益为12.54dB的增益模块。如果左声道和右声道

完全不相关，则选用9.54dB的增益模块。音频部分的功能框图见图3和图4。

无杂音切换

TV通道包含过零检测 (ZCD) 电路，当在任意时刻切换两个音频信号时，该电路可以将信号电平突变所产生的噪声降至最低。



图3. MAX4397D 音频部分功能框图

用于双路SCART连接器的音频/视频开关

MAX4397

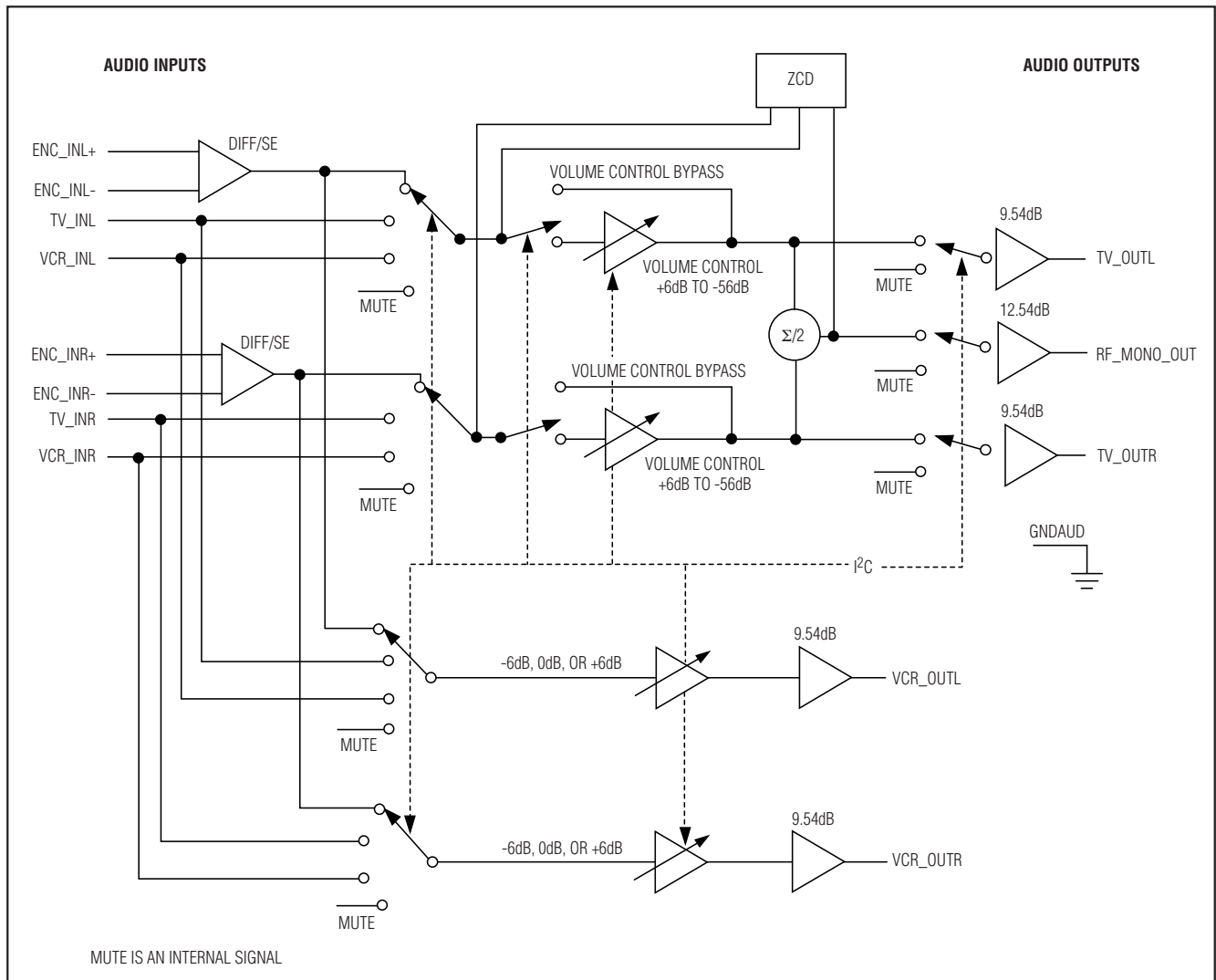

图4. MAX4397S 音频部分，具有单端编码器输入

为在切换音频信号时实现过零检测功能，可通过 I²C 兼容接口写寄存器 00h 并使 ZCD 位置高 (如果 ZCD 位还未置高)。然后写寄存器 00h 将 mute 位置低。接下来，等待足够

长的时间，以使音频信号过零。该时间段是音频信号通路低频 3dB 转角频率 (f_{L3dB}) 的函数。因此，如果 $f_{L3dB} = 1\text{kHz}$ ，过零检测要等待的时间长度为 $1/2\text{kHz}$ 或 0.5ms 。

用于双路SCART连接器的音频/视频开关

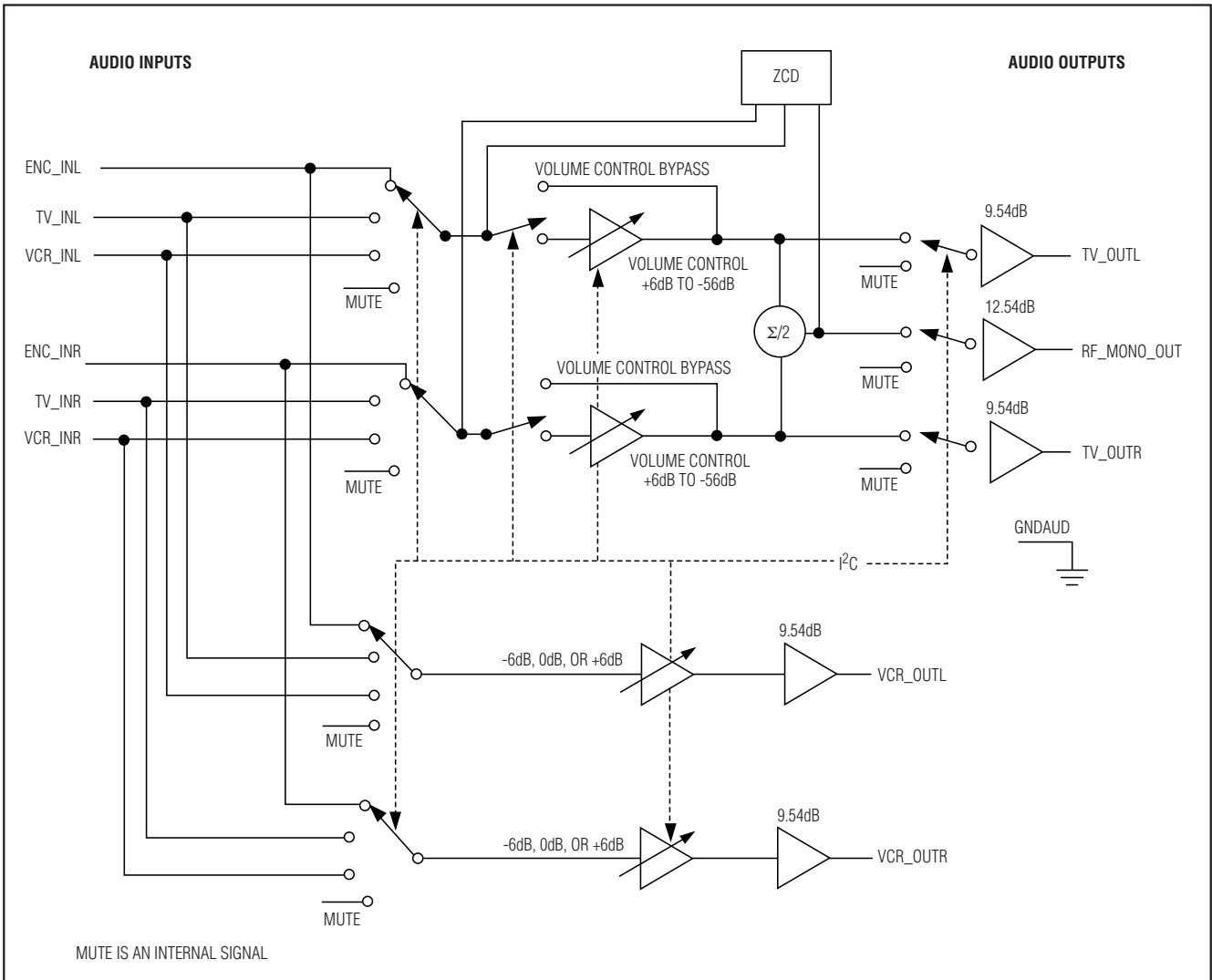
音量控制

TV通道音量控制的范围为-56dB到+6dB，步长为2dB。VCR音量控制可以编程设置为-6dB、0dB、+6dB。增益等级以具体应用的输入值为参考，其中提供有分压器。ZCD位置高后，TV音量控制只在过零时进行转换，从而将杂音降至最低。TV输出可以旁路掉音量控制。同样，TV音量控制可以处理单声道输出信号，单声道输出信号也可以旁路掉音量控制。

数字部分

串行接口

MAX4397带有简单的2线串行接口，只需要两个标准微处理器I/O口线。快速模式I²C兼容串行接口允许通信数据速率高达400kbps或400kHz。图5给出了2线接口的信号时序图。

空闲时两根总线 (SDA和SCL) 必须置为逻辑高电平。MAX4397是从器件，必须由主机设备来控制。若不是由推挽电路驱动总线时，总线和电源之间需接上拉电阻。

只有当SCL为低时，SDA的逻辑电平才能发生改变。SCL为高时若SDA转换为高/低电平，将产生启动和停止条件(见图5)。在SCL变为高电平之前的建立时间 ($t_{SU,DAT}$) 内，SDA上的数据必须保持稳定。当SCL转换为高时采样SDA上的数据，并且SDA上的数据在保持时间 ($t_{HD,DAT}$) 内保持稳定。注意，数据是以8位字节的形式发送的。向MAX4397传送一个字节共需9个时钟周期。在第9个时钟周期，器件将拉低SDA以应答成功接收的字节。



图5. SDA和SCL信号时序图

用于双路SCART连接器的音频/视频开关

2线接口数据格式

编程设置

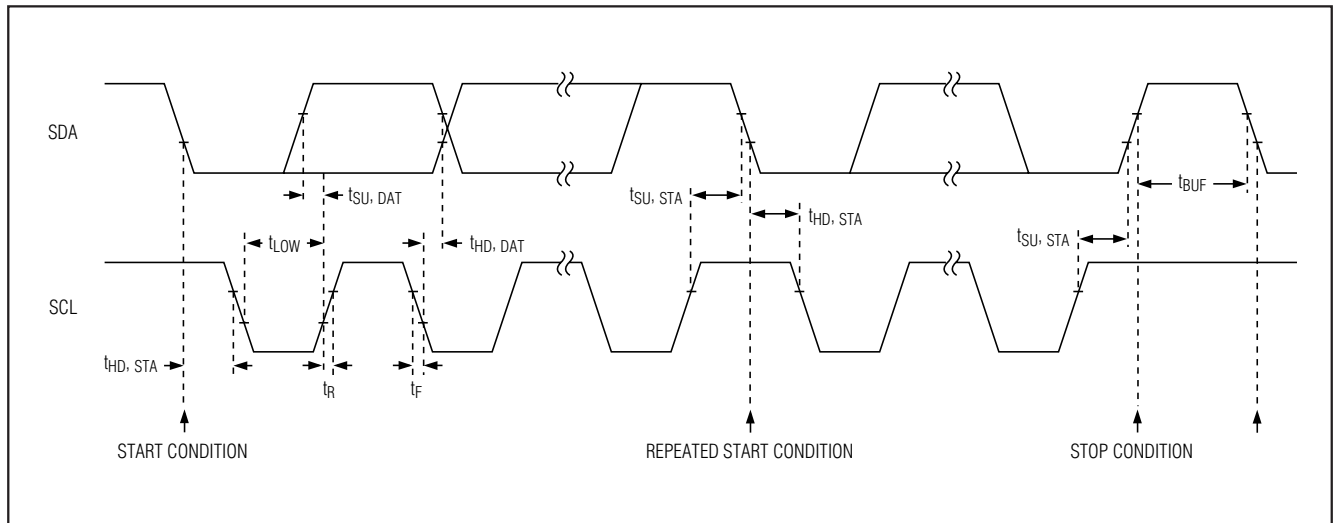
写和读模式

S	Slave Address	A	Register Address	A	Data2	A	P
---	---------------	---	------------------	---	-------	---	---

S = 启动条件, A = 应答, P = 停止条件

I²C兼容接口

MAX4397与现有的I²C系统兼容。SCL和SDA是高阻输入。SDA具有漏极开路输出,可在第9个时钟脉冲时将总线拉至逻辑低电平。图6给出了一个典型的I²C接口应用。通信协议支持标准I²C 8位通信方式。MAX4397地址只与7位I²C地址协议兼容,不支持10位地址格式。

数字输入及接口逻辑

I²C兼容2线接口的逻辑电平定义为: $V_{IL} = 0.8V$, $V_{IH} = 2.0V$ 。所有输入都包括Schmitt触发器缓冲器,支持低速转换接口。数字输入兼容3V CMOS逻辑电平。



图6. 典型I²C接口应用

将DEV_ADDR接地,可以设置MAX4397的写地址和读地址,如表2所示。

表2. 设置从地址

ADDRESS PIN STATE	WRITE ADDRESS	READ ADDRESS
VVID	96h	97h
GNDVID	94h	95h

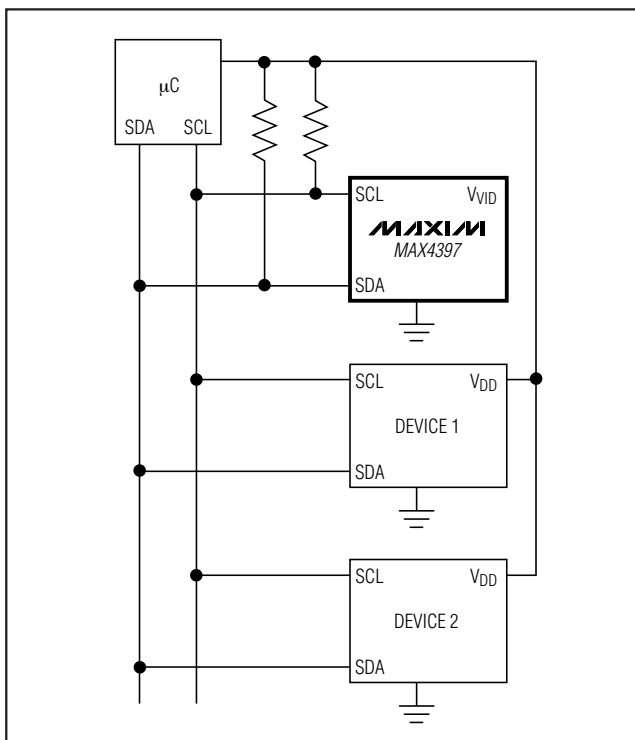
读写数据寄存器

通过写寄存器00h至0Dh,可以对SCART视频和音频切换进行编程设置。也可以对寄存器00h至0Eh进行读操作,允许编程之后回读数据,并便于系统调试。状态寄存器是只读的,可从地址0Eh处读取。寄存器编程信息见表3-12。

应用信息

热插拔SCART连接器

MAX4397的所有SCART输入和输出均具有高ESD保护功能,无需外部瞬态电压抑制(TVS)器件即可对浮空的机壳放电提供保护。由于一些机顶盒的机壳没有连接到大地,因此存在浮空机壳问题。这种情况下机壳电压可充至500V电压。当SCART电缆连接至SCART连接器时,被充电的机壳会通过信号引脚放电。等效电路为:充电至311V的2200pF电容通过一个阻值小于0.1Ω的电阻与信号引脚相连。焊接在电路板上的MAX4397会经受这样一次放电过程。因此,电流尖峰流过ESD保护二极管,并由电源旁路电容吸收,旁路电容具有大容值和低ESR。

当电缆放电时,为更好地保护MAX4397免受高电压损害,可在SCART连接器的所有输入和输出端额外串联75Ω电阻。恶劣环境下要求具有±15kV静电保护,可以选用MAX4385E和MAX4386E单路及四路高速运算放大器,这是业界首次在视频输入和输出端集成了±15kV ESD保护的两款器件。

用于双路SCART连接器的音频/视频开关

电源及旁路

MAX4397采用单5V和12V供电，无需负电源。+12V电源V₁₂用于SCART切换功能。用并联的10 μ F电容和0.1 μ F陶瓷电容旁路V₁₂引脚，且所有电容要尽可能靠近该引脚安装。所有V_{AUD}引脚应连接在一起并连接至+5V电源，用并联的10 μ F电解电容与0.47 μ F低ESR陶瓷电容将其旁路至音频地。用0.1 μ F电容旁路V_{AUD}引脚至音频地。用并联的10 μ F电解电容与0.1 μ F陶瓷电容旁路AUD_BIAS至音频地。

用一个0.1 μ F陶瓷电容旁路V_{DIG}至数字地。用一个0.1 μ F陶瓷电容旁路V_{VID}至视频地。V_{VID}与+5V电源之间串联一个200nH铁氧体磁珠。

布局及接地

为获得最佳性能，视频信号通路应使用受控阻抗走线，并且输入端接电阻和输出背向端接电阻应靠近MAX4397放置。视频走线应避免与高速数据线平行。

MAX4397为视频、音频和数字电源提供单独的接地点。为获得最佳性能，每个地回路应使用单独的地层，并且三个地层通过单点连接。参考MAX4397评估板，其中给出了一个经过验证的电路板布局实例。

表3. 写模式的数据格式

REGISTER ADDRESS (HEXADECIMAL)	BIT 7	BIT 6	BIT 5	BIT 4	BIT 3	BIT 2	BIT 1	BIT 0
00h	TV volume bypass	ZCD	TV volume control					TV audio output mute
01h	VCR volume control		Not used	Not used	VCR audio selection		TV audio selection	
02h	Not used							
03h	Not used							
04h	Not used							
05h	Not used							
06h	TV_R/C_IN clamp	RGB gain		TV G and B video switch		TV video switch		
07h	Not used	RF_CVBS_OUT switch	TV_Y/CVBS_OUT switch	TV fast blank (fast switching)		TV_R/C_OUT ground	Set function TV	
08h	VCR_R/C_IN clamp	Not used	Not used	Not used	ENC_R/C_IN clamp	VCR video switch		
09h	Not used	Not used	Not used	Not used	Not used	VCR_R/C_OUT ground	Set function VCR	
0Ah	Not used							
0Bh	Not used							
0Ch	Not used							
0Dh	VCR_Y/CVBS_OUT enable	VCR_R/C_OUT enable	TV_R/C_OUT enable	TV_G_OUT enable	TV_B_OUT enable	TV_Y/CVBS_OUT enable	TVOUT_FS enable	RF_CVBS_OUT enable

用于双路SCART连接器的音频/视频开关

表4. 读模式的数据格式

REGISTER ADDRESS (HEXADECIMAL)	BIT 7	BIT 6	BIT 5	BIT 4	BIT 3	BIT 2	BIT 1	BIT 0
0Eh	Thermal SHDN	Power-on reset	Not used		VCR slow switch input		TV slow switch input	

表5. 寄存器00h: TV音频控制

DESCRIPTION	BIT								COMMENTS
	7	6	5	4	3	2	1	0	
TV Audio Mute								0	Off
								1	On (power-on default)
TV Volume Control			0	0	0	0	0		+6dB gain
			0	0	0	0	1		+4dB gain
			0	0	0	1	0		+2dB gain
			0	0	0	1	1		0dB gain (power-on default)
			0	0	1	0	0		-2dB gain
			0	0	1	0	1		-4dB gain
			1	1	1	1	0		-54dB gain
TV Zero-Crossing Detector		0							Off
		1							On (power-on default)
TV Volume Bypass	0								TV audio passes through volume control (power-on default)
	1								TV audio bypasses volume control

表6. 寄存器01h: TV/VCR音频控制

DESCRIPTION	BIT								COMMENTS
	7	6	5	4	3	2	1	0	
Input Source for TV Audio							0	0	Encoder audio
							0	1	VCR audio
							1	0	TV audio
							1	1	Mute (power-on default)
Input Source for VCR Audio					0	0			Encoder audio
					0	1			VCR audio
					1	0			TV audio
					1	1			Mute (power-on default)
VCR Volume Control	0	0							0dB gain (power-on default)
	0	1							+6dB gain
	1	0							-6dB gain
	1	1							0dB gain

用于双路SCART连接器的音频/视频开关

表7. 寄存器06h: TV视频输入控制

DESCRIPTION	BIT								COMMENTS	
	7	6	5	4	3	2	1	0		
Input Sources for TV Video									TV_Y/CVBS_OUT	TV_R/C_OUT
						0	0	0	ENC_Y/CVBS_IN	ENC_R/C_IN
						0	0	1	ENC_Y_IN	ENC_C_IN
						0	1	0	VCR_Y/CVBS_IN	VCR_R/C_IN
						0	1	1	TV_Y/CVBS_IN	TV_R/C_IN
						1	0	0	Not used	Not used
						1	0	1	Mute	Mute
						1	1	0	Mute	Mute
						1	1	1	Mute (power-on default)	Mute (power-on default)
Input Sources for TV_G_OUT and TV_B_OUT				0	0				TV_G_OUT	TV_B_OUT
				0	1				ENC_G_IN	ENC_B_IN
				1	0				VCR_G_IN	VCR_B_IN
				1	1				Mute	Mute
RGB Gain		0	0						Mute (power-on default)	Mute (power-on default)
		0	1						6dB (power-on default)	
		1	0						7dB	
		1	1						5dB	
TV_R/C_IN Clamp/Bias	0								DC restore clamp active at input (power-on default)	
	1								Chrominance bias applied at input	

用于双路SCART连接器的音频/视频开关

表8. 寄存器07h: TV视频输出控制

DESCRIPTION	BIT								COMMENTS
	7	6	5	4	3	2	1	0	
Set TV Function Switching							0	0	Low (<2V), internal source (power-on default)
							0	1	Medium (4.5V to 7V), external SCART source with 16:9 aspect ratio
							1	0	High impedance
							1	1	High (>9.5V), external SCART source with 4:3 aspect ratio
TV_R/C_OUT Ground						0			Normal operation, pulldown on TV_R/C_OUT is off (power-on default)
						1			Ground, pulldown on TV_R/C_OUT is on, the output amplifier driving TV_R/C_OUT is turned off
Fast Blank (Fast Switching)				0	0				0V (power-on default)
				0	1				Same level as ENC_FB_IN
				1	0				Same level as VCR_FB_IN
				1	1				V _{VID}
TV_Y/CVBS_OUT Switch			0						Composite video from the Y/C mixer is output
			1						The TV_Y/CVBS_OUT signal selected in register 06h is output (power-on default)
RF_CVBS_OUT Switch		0							Composite video from the Y/C mixer is output (power-on default)
		1							The TV_Y/CVBS_OUT signal selected in register 06h is output

表9. 寄存器08h: VCR视频输入控制

DESCRIPTION	BIT								COMMENTS	
	7	6	5	4	3	2	1	0		
Input Sources for VCR Video									VCR_Y/CVBS_OUT	VCR_R/C_OUT
						0	0	0	ENC_Y/CVBS_IN	ENC_R/C_IN
						0	0	1	ENC_Y_IN	ENC_C_IN
						0	1	0	VCR_Y/CVBS_IN	VCR_R/C_IN
						0	1	1	TV_Y/CVBS_IN	TV_R/C_IN
						1	0	0	Not used	Not used
						1	0	1	Mute	Mute
						1	1	0	Mute	Mute
VCR_R/C_IN Clamp/Bias						1	1	1	Mute (power-on default)	Mute (power-on default)
	0								DC restore clamp active at input (power-on default)	
ENC_R/C_IN Clamp/Bias	1								Chrominance bias applied at input	
					0				DC restore clamp active at input (power-on default)	
ENC_R/C_IN Clamp/Bias					1				Chrominance bias applied at input	

用于双路SCART连接器的音频/视频开关

表 10. 寄存器 09h: VCR 视频输出控制

DESCRIPTION	BIT								COMMENTS
	7	6	5	4	3	2	1	0	
Set VCR Function Switching							0	0	Low (<2V), internal source (power-on default)
							0	1	Medium (4.5V to 7V), external SCART source with 16:9 aspect ratio
							1	0	High impedance
							1	1	High (>9.5V), external SCART source with 4:3 aspect ratio
VCR_R/C_OUT ground						0			Normal operation, pulldown on VCR_R/C_OUT is off (power-on default)
						1			Ground, pulldown on VCR_R/C_OUT is on, the output amplifier driving VCR_R/C_OUT is turned off

表 11. 寄存器 0Dh: 输出使能

DESCRIPTION	BIT								COMMENTS
	7	6	5	4	3	2	1	0	
RF_CVBS_OUT								0	Off (power-on default)
								1	On
TVOUT_FS								0	Off (power-on default)
								1	On
TV_Y/CVBS_OUT						0			Off (power-on default)
						1			On
TV_B_OUT					0				Off (power-on default)
					1				On
TV_G_OUT				0					Off (power-on default)
				1					On
TV_R/C_OUT			0						Off (power-on default)
			1						On
VCR_R/C_OUT		0							Off (power-on default)
		1							On
VCR_Y/CVBS_OUT	0								Off (power-on default)
	1								On

用于双路SCART连接器的音频/视频开关

MAX4397

表 12. 寄存器0Eh状态

DESCRIPTION	BIT								COMMENTS
	7	6	5	4	3	2	1	0	
TV Slow Switch Input							0	0	0 to 2V, internal source
							0	1	4.5V to 7V, external source with 16:9 aspect ratio
							1	0	Not used
							1	1	9.5V to 12.6V, external source with 4:3 aspect ratio
VCR Slow Switch Input					0	0			0 to 2V, internal source
					0	1			4.5V to 7V, external source with 16:9 aspect ratio
					1	0			Not used
					1	1			9.5V to 12.6V, external source with 4:3 aspect ratio
Power-On Reset		0							V _{VID} is too low for digital logic to operate
		1							V _{VID} is high enough for digital logic to operate
Thermal Shutdown	0								The part is in thermal shutdown
	1								The temperature is below the TSHD limit

用于双路SCART连接器的音频/视频开关

典型应用电路

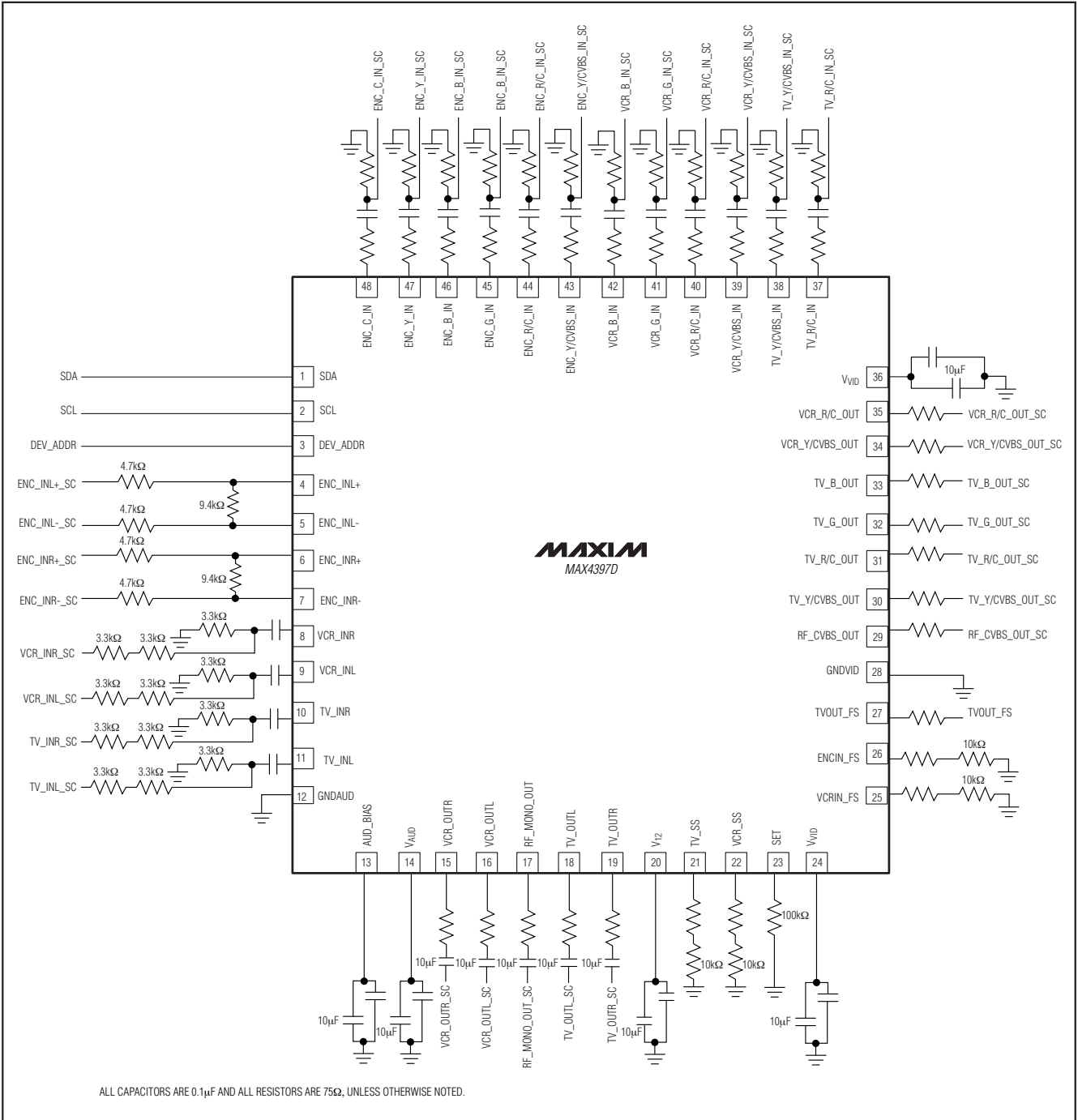

用于双路SCART连接器的音频/视频开关

典型应用电路 (续)

MAX4397

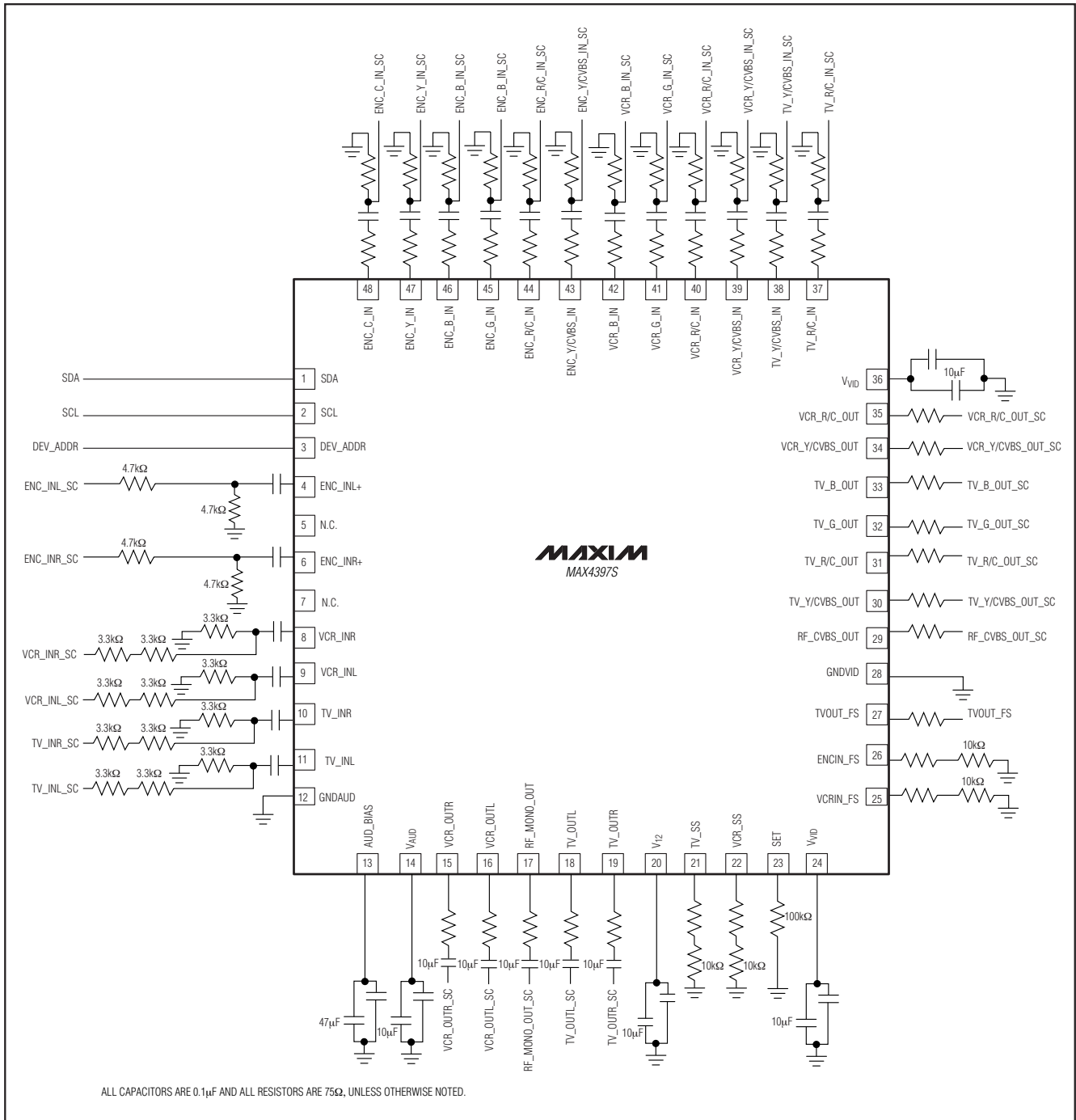

用于双路SCART连接器的音频/视频开关

系统框图

MAX4397

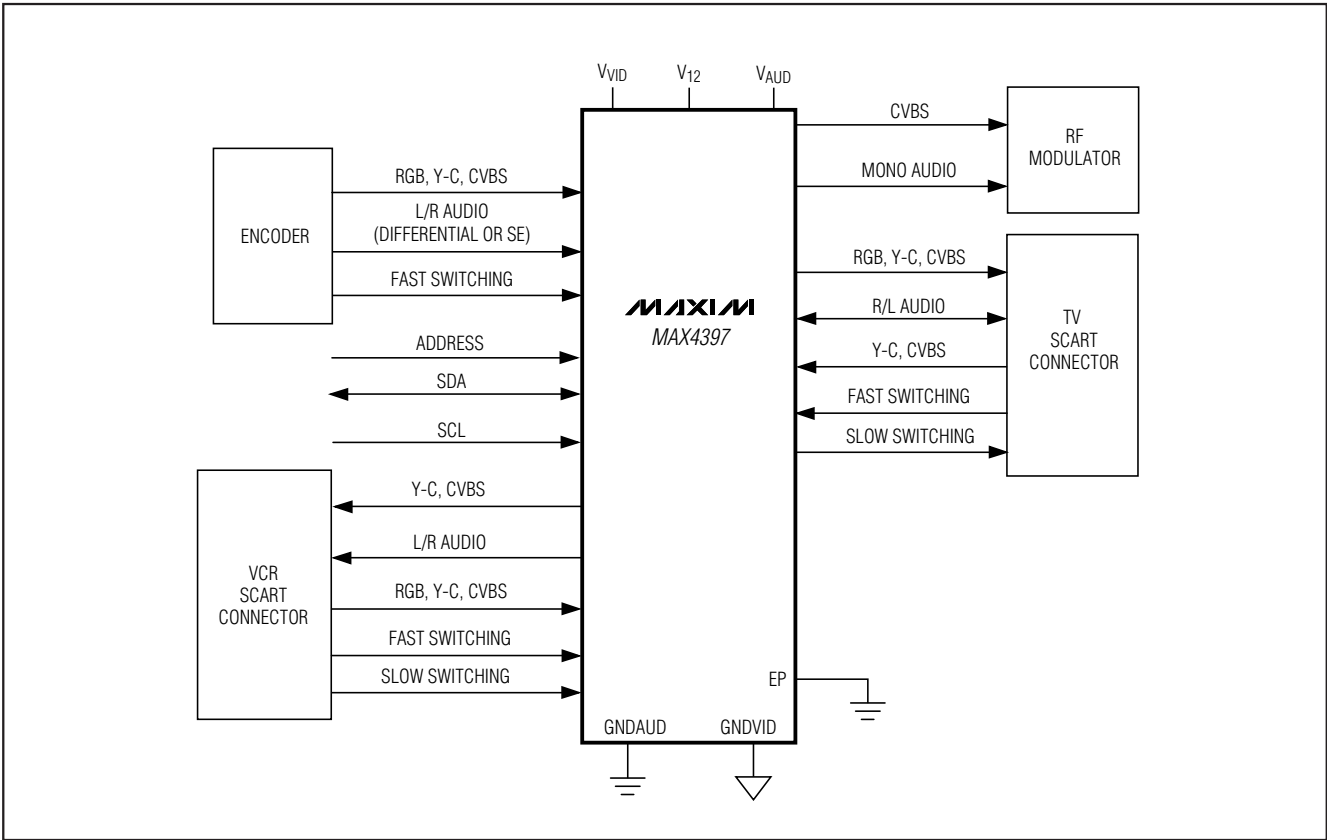

用于双路SCART连接器的音频/视频开关

引脚配置

MAX4397

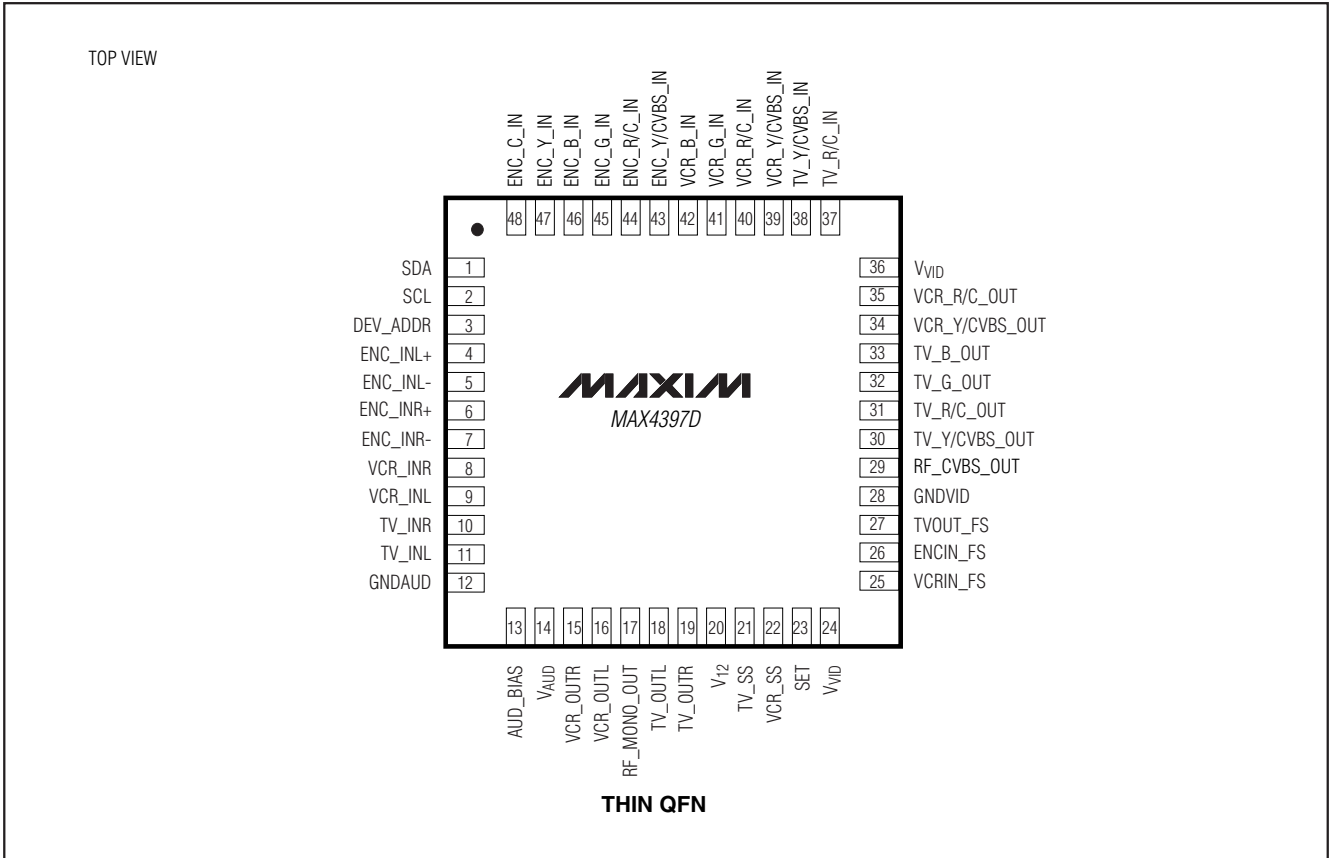

用于双路SCART连接器的音频/视频开关

引脚配置 (续)

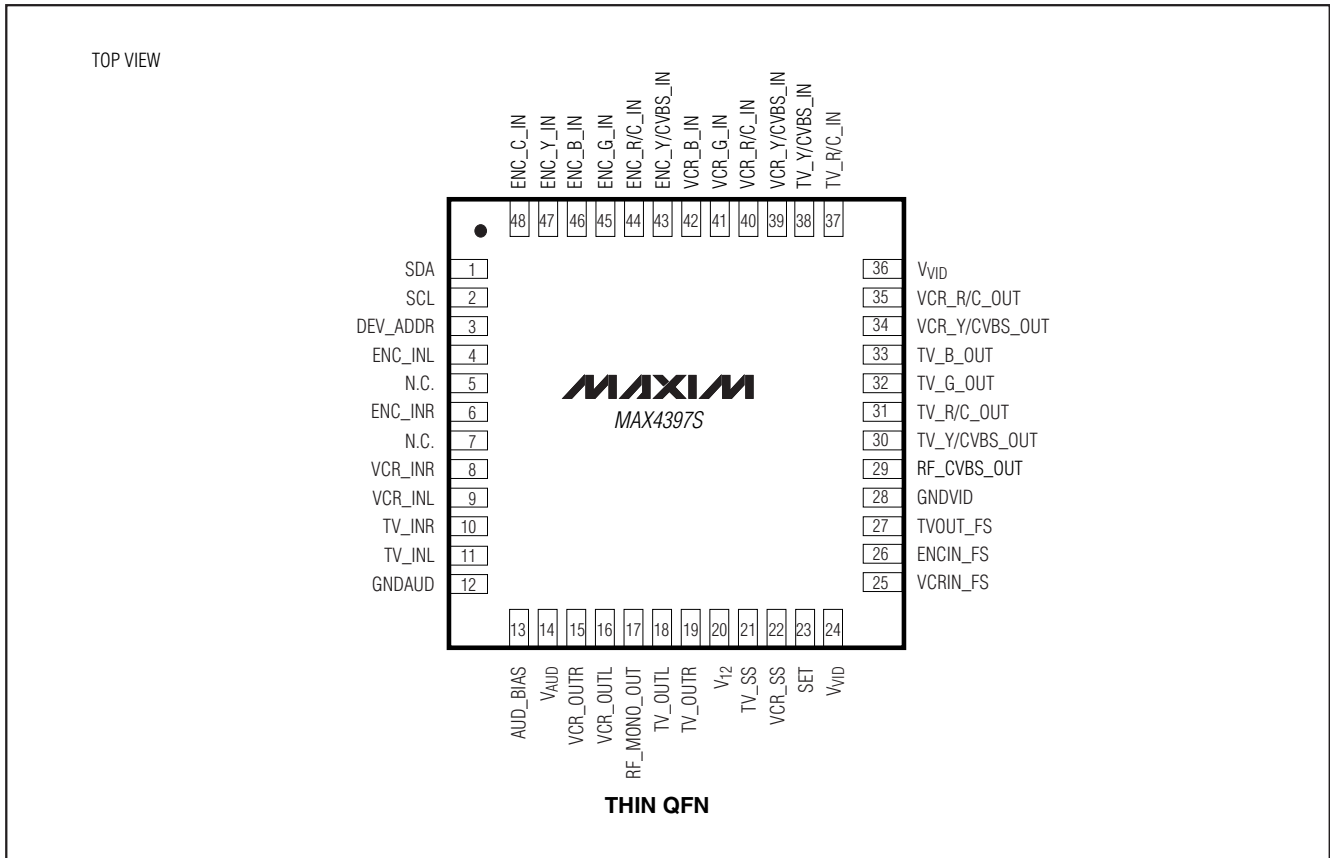

芯片信息

TRANSISTOR COUNT: 13,265

PROCESS: BiCMOS

用于双路 SCART 连接器的音频/视频开关

封装信息

(本数据资料提供的封装图可能不是最近的规格，如需最近的封装外型信息，请查询 www.maxim-ic.com.cn/packages.)

MAX4397

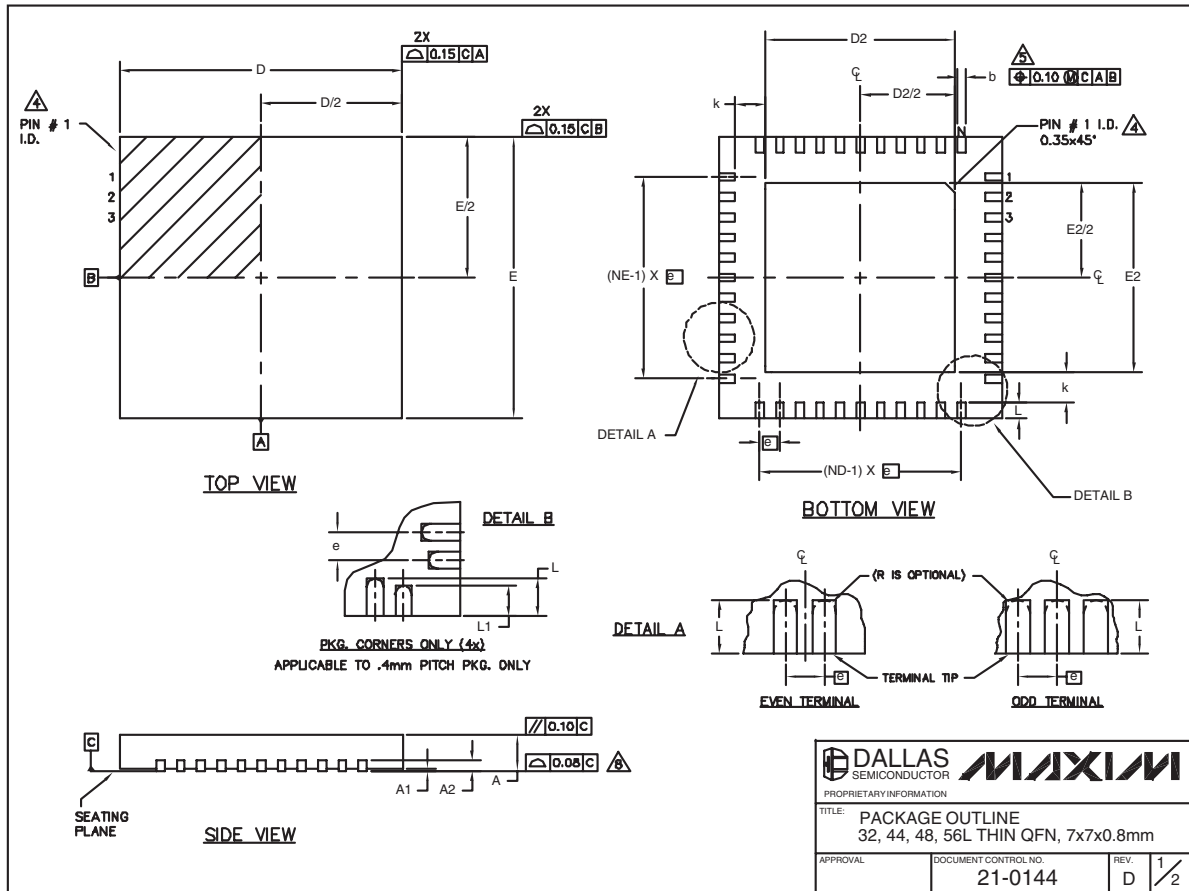

32, 44, 48L QFN:EPS

用于双路SCART连接器的音频/视频开关

封装信息 (续)

(本数据资料提供的封装图可能不是最近的规格, 如需最近的封装外型信息, 请查询 www.maxim-ic.com.cn/packages.)

COMMON DIMENSIONS															
PKG	32L 7x7			44L 7x7			48L 7x7			CUSTOM PKG. (T4877-1) 48L 7x7			56L 7x7		
SYMBOL	MIN.	NOM.	MAX.	MIN.	NOM.	MAX.	MIN.	NOM.	MAX.	MIN.	NOM.	MAX.	MIN.	NOM.	MAX.
A	0.70	0.75	0.80	0.70	0.75	0.80	0.70	0.75	0.80	0.70	0.75	0.80	0.70	0.75	0.80
A1	0	0.02	0.05	0	0.02	0.05	0	0.02	0.05	0	0.02	0.05	0	-	0.05
A2	0.20 REF.			0.20 REF.			0.20 REF.			0.20 REF.			0.20 REF.		
b	0.25	0.30	0.35	0.20	0.25	0.30	0.20	0.25	0.30	0.20	0.25	0.30	0.15	0.20	0.25
D	6.90	7.00	7.10	6.90	7.00	7.10	6.90	7.00	7.10	6.90	7.00	7.10	6.90	7.00	7.10
E	6.90	7.00	7.10	6.90	7.00	7.10	6.90	7.00	7.10	6.90	7.00	7.10	6.90	7.00	7.10
e	0.65 BSC.			0.50 BSC.			0.50 BSC.			0.50 BSC.			0.40 BSC.		
k	0.25	-	-	0.25	-	-	0.25	-	-	0.25	-	-	0.25	0.35	0.45
L	0.45	0.55	0.65	0.45	0.55	0.65	0.30	0.40	0.50	0.45	0.55	0.65	0.40	0.50	0.60
L1	-	-	-	-	-	-	-	-	-	-	-	-	0.30	0.40	0.50
N	32			44			48			44			56		
ND	8			11			12			10			14		
NE	8			11			12			12			14		

EXPOSED PAD VARIATIONS									
PKG. CODES	DEPOPULATED LEADS	D2			E2			JEDEC MO220 REV. C	DOWN BONDS ALLOWED
		MIN.	NOM.	MAX.	MIN.	NOM.	MAX.		
T3277-1	-	4.55	4.70	4.85	4.55	4.70	4.85	-	NO
T3277-2	-	4.55	4.70	4.85	4.55	4.70	4.85	-	YES
T4477-1	-	4.55	4.70	4.85	4.55	4.70	4.85	WKKD-1	NO
T4477-2	-	4.55	4.70	4.85	4.55	4.70	4.85	WKKD-1	YES
T4477-3	-	4.55	4.70	4.85	4.55	4.70	4.85	WKKD-1	YES
T4877-1**	13,24,37,48	4.20	4.30	4.40	4.20	4.30	4.40	-	NO
T4877-2	-	5.45	5.60	5.63	5.45	5.60	5.63	-	NO
T4877-3	-	4.95	5.10	5.25	4.95	5.10	5.25	-	YES
T4877-4	-	5.45	5.60	5.63	5.45	5.60	5.63	-	YES
T4877-5	-	2.40	2.50	2.60	2.40	2.50	2.60	-	NO
T4877-6	-	5.45	5.60	5.63	5.45	5.60	5.63	-	NO
T5677-1	-	5.20	5.30	5.40	5.20	5.30	5.40	-	YES

** NOTE: T4877-1 IS A CUSTOM 48L PKG. WITH 4 LEADS DEPOPULATED. TOTAL NUMBER OF LEADS ARE 44.

NOTES:

- DIMENSIONING & TOLERANCING CONFORM TO ASME Y14.5M-1994.
- ALL DIMENSIONS ARE IN MILLIMETERS. ANGLES ARE IN DEGREES.
- N IS THE TOTAL NUMBER OF TERMINALS.
- THE TERMINAL #1 IDENTIFIER AND TERMINAL NUMBERING CONVENTION SHALL CONFORM TO JESD 95-1 SPP-012. DETAILS OF TERMINAL #1 IDENTIFIER ARE OPTIONAL, BUT MUST BE LOCATED WITHIN THE ZONE INDICATED. THE TERMINAL #1 IDENTIFIER MAY BE EITHER A MOLD OR MARKED FEATURE.
- DIMENSION b APPLIES TO METALLIZED TERMINAL AND IS MEASURED BETWEEN 0.25 mm AND 0.30 mm FROM TERMINAL TIP.
- ND AND NE REFER TO THE NUMBER OF TERMINALS ON EACH D AND E SIDE RESPECTIVELY.
- DEPOPULATION IS POSSIBLE IN A SYMMETRICAL FASHION.
- COPLANARITY APPLIES TO THE EXPOSED HEAT SINK SLUG AS WELL AS THE TERMINALS.
- DRAWING CONFORMS TO JEDEC MO220 EXCEPT THE EXPOSED PAD DIMENSIONS OF T3277-1; T4877-1/-2/-3/-4/-5/-6 & T5677-1.
- WARPAGE SHALL NOT EXCEED 0.10 mm.

PROPRIETARY INFORMATION TITLE: PACKAGE OUTLINE 32, 44, 48, 56L THIN QFN, 7x7x0.8mm	
APPROVAL	DOCUMENT CONTROL NO. 21-0144
REV. D	2/2

MAXIM北京办事处

北京 8328 信箱 邮政编码 100083

免费电话: 800 810 0310

电话: 010-6201 0598

传真: 010-6201 0298

Maxim 不对 Maxim 产品以外的任何电路使用负责, 也不提供其专利许可。Maxim 保留在任何时间、没有任何通报的前提下修改产品资料和规格的权利。

30 _____ **Maxim Integrated Products, 120 San Gabriel Drive, Sunnyvale, CA 94086 408-737-7600**